



HAYWARD Hi-Performance SELF-PRIMING PUMPS INSTALLATION AND OPERATING INSTRUCTIONS

Turbo Flo II™

Your Hayward Turbo Flo II pump has been quality and engineered to give you many years of efficient, dependable service. The non-conductive, corrosion-proof motor housing provides protection from the elements and insulates the electrical motor parts from outside contact.

The advanced design reduced operation and maintenance to simple, common-sense procedures.

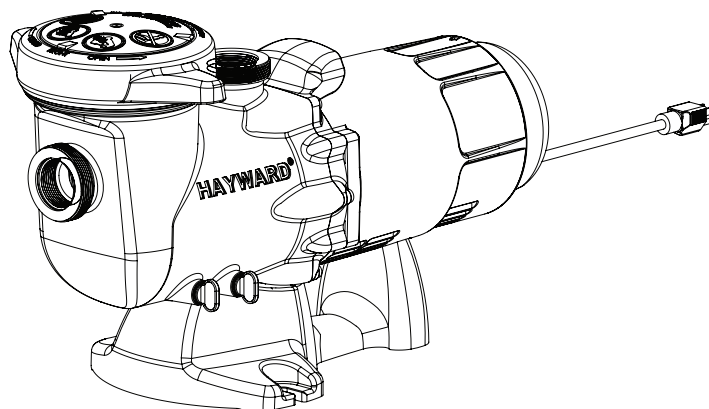

GENERAL TIPS ON PUMP INSTALLATION

For best pump performance, locate the system below the pool water line and as close to the pool as possible. If you own an above ground pool please see Note: NSPI-4 Article V, for safe and proper installation of the equipment package. Make sure suction joints are tight. Suction pipe should be as large or larger than discharge pipe.

Damp, non-ventilated locations should be avoided. Motors require free circulation of air to aid in cooling.

Insure that the electrical supply available agrees with the motor's voltage, phase and cycle, and that wire size is adequate for the HP/KW rating and distance from the power source. Motor must always be properly grounded. If cord connected, use only a properly grounded outlet. Electrical circuits should be protected by proper size ground fault circuit interrupter (GFCI). All electrical wiring should be performed by qualified personnel and must conform to local codes and regulations.

STARTING AND PRIMING INSTRUCTIONS

Fill strainer/housing completely with water. Never operate the pump without water. Water acts as a coolant and lubricant for the mechanical shaft seal.

Open all suction and discharge lines and valves, as well as air bleed (if available) on filter. (The air that is to be displaced from the suction line must have some place to go).

Turn on power and allow a reasonable time for priming. Priming time depends on suction lift and length of suction piping. If pump will not start, or will not prime, see TROUBLE SHOOTING GUIDE on back page.

Note: NSPI-4 Article V, standard for above ground and on ground pools, advises that components such as the filtration system, pumps and heater be positioned so as to prevent their being used as a means of access to the pool by young children.

MAINTENANCE

1. Clean strainer basket regularly. Do not strike basket to clean. Inspect strainer cover gasket regularly and replace as necessary.
2. Hayward pumps have self-lubricating motor bearings and shaft seals. No lubrication is necessary.
3. Keep motor housing clean. Insure air vents are free from obstructions, debris, etc.

4. Occasionally, shaft seals must be replaced, due to wear or damage. See instructions

STORAGE/WINTERIZING

Pump and motor must be protected from freezing. Shut off all electric power. Disconnect cord/electrical connections and plumbing connections. Drain thoroughly and clean out any debris. Store pump and motor in a dry, well ventilated room.

MANUFACTURED EXCLUSIVELY BY HAYWARD

2880 PLYMOUTH DRIVE, OAKVILLE, ONTARIO L6H 5R4 • 1-888-238-POOL

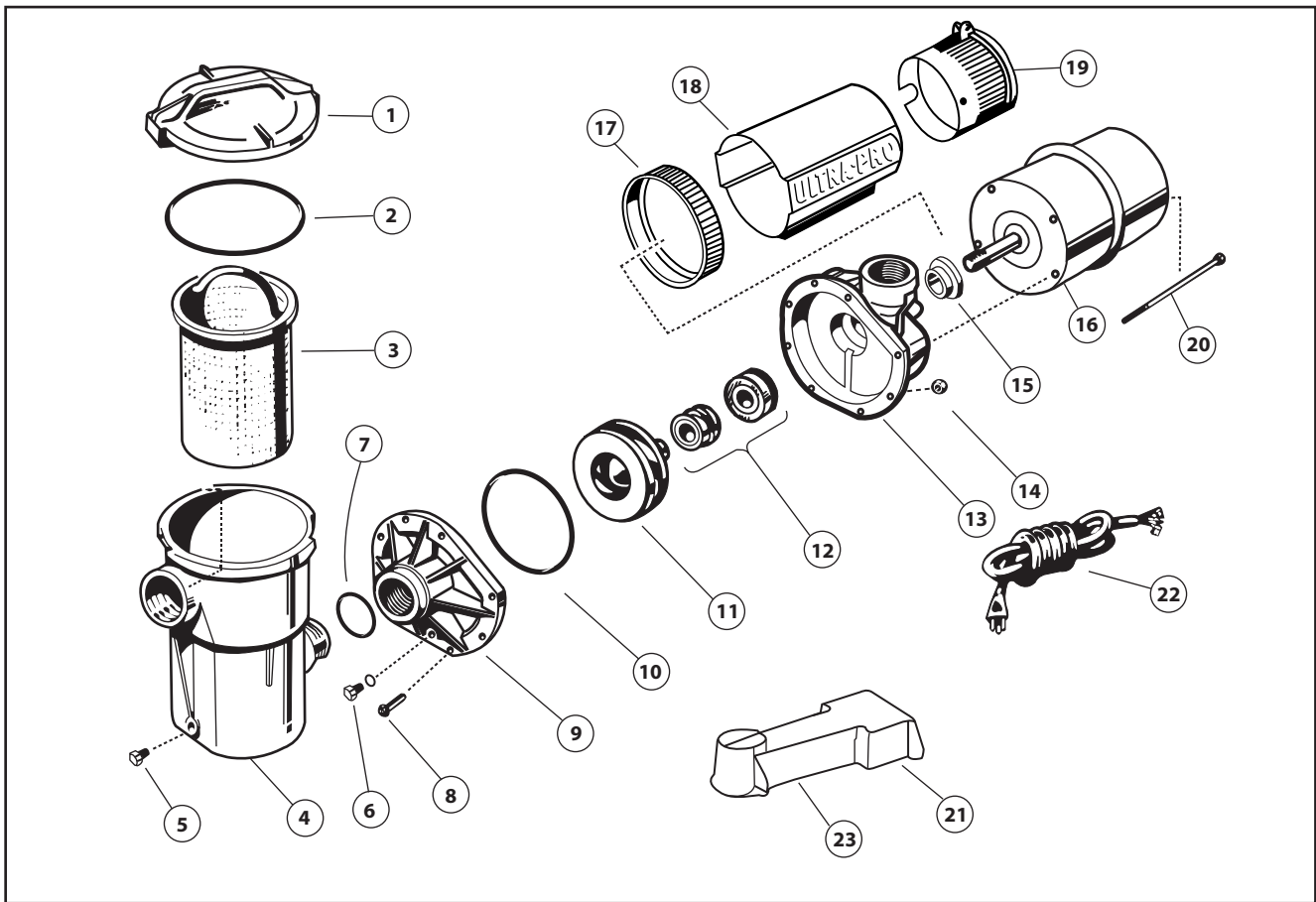

Ref No.	DESCRIPTION	No. Req'd	PART NUMBER	
			MODEL SP2290 (ET)	MODEL SP-2295 (ET)
1	Strainer Cover	1	SP1680E	SP1680E
2	Strainer Cover w/o-ring	1	SP1500P	SP1500P
3	Basket	1	SP1500LX	SP1500LX
4	Strainer Housing	1	SP1500CP	SP1500CP
5	Drain Plug (optional)	--	SP1700FG	SP1700FG
6	Drain Plug w/Gasket	1	SP1700FG	SP1700FG
7	O-ring	1	SP1500W	SP1500W
8	Bolt, No. 10-24 Hex. Head	8	SP1500N2	SP1500N2
9	Housing Cover	1	SP1580BP	SP1580BP
10	Housing O-ring	1	SP1580Z1	SP1580Z1
11	Impeller	1	SP1500E	SP1500F
12	Seal Assembly	1	SP1500KA	SP1500KA
13	Pump Housing	1	SP1580AAP	SP1580AAP
14	Nut, No. 10-24 Hex	8	SP1500Y2	SP1500Y2
15	Shaft Sleeve	1	SP1500Q5	SP1500Q5
16	Motor	1	SP1509ZIUF	SP1514ZIUF
17	Shroud	1	SP2090B	SP2090B
18	Motor Housing	1	SP2090A	SP2090A
19	Motor End Cover	1	SP2090CAM	SP2090CAM
19b	Timer End Cover (Electronic) (ET)	Optional	SP2090CETM	SP2090CETM
20	Motor-To-Housing bolt	4	To order, specify manufacturer, HP and Model No.	
21	Elevated Mounting Base	1	SP5500M	SP5500M
22	Power Cord	1	SP1550WA7C	SP1550WA7C
23	Base Noise Reduction Insert	1	SP5500MFB	SP5500MFB

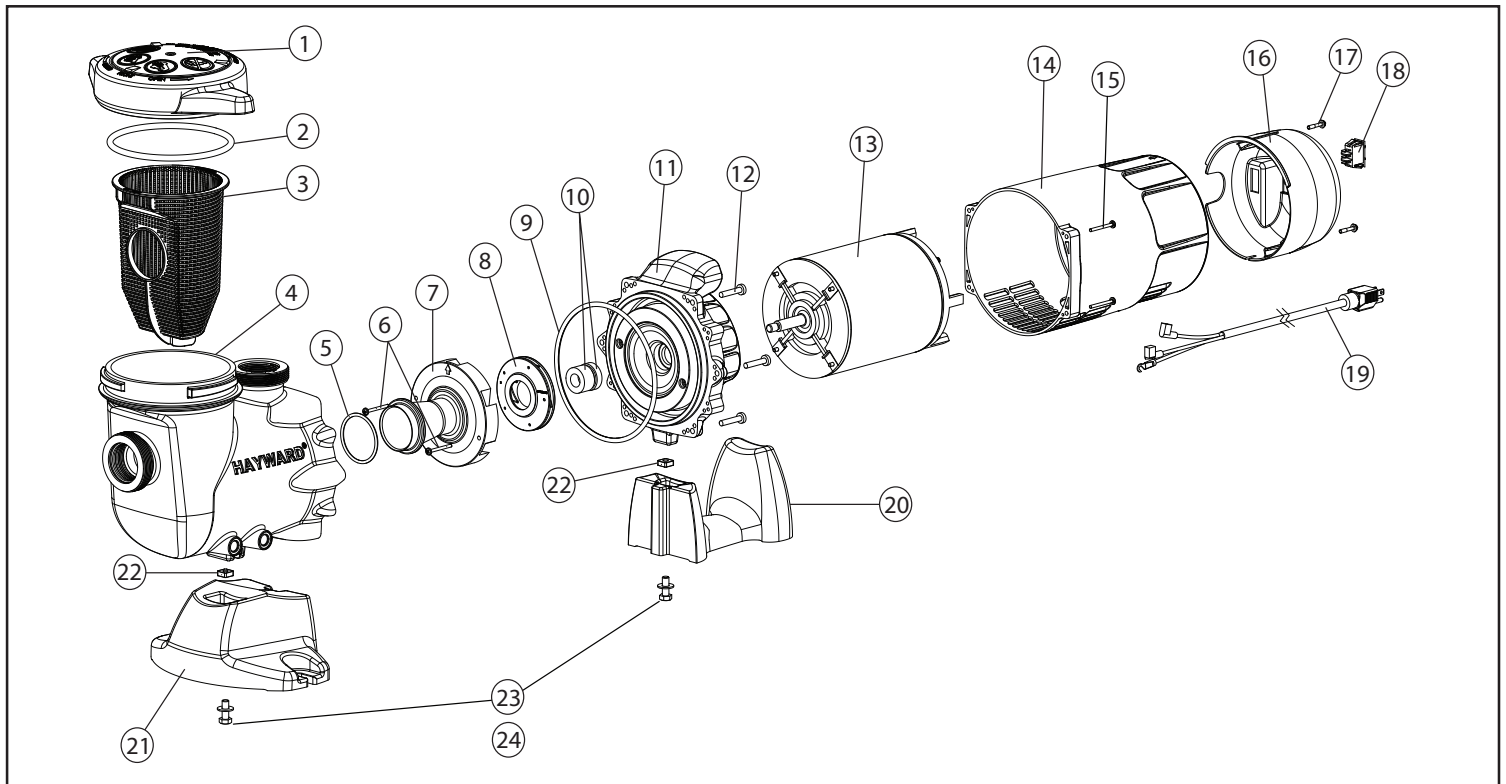

PARTS LISTING

Ref No.	Part#	Description	No. Required
1	SP5700DL	Strainer Cover Assy	1
2	SP2700Z4	Strainer O-ring	1
3	SP2700M	Strainer Basket	1
4	SP5700A	Pump Housing	1
5	SP1495Z1	O-ring	1
6	SP2700Z3	Screw	2
7	SP5700B	Diffuser	1
8a	SP1591E	1 HP Impeller	1
8b	SP1591F	1.5 HP Impeller	1
9	SP5500H	O-ring	1
10	SP1250XZ2C	Shaft Seal	1
11	SP5700E	Seal Plate	1
12	6060Z1	Screw	6
13a	SP1509Z1UF	1 HP Motor	1
13b	SP1509Z2UF	1 HP 2 SP Motor	1
13c	SP1514Z1UF	1.5 HP Motor	1
13d	SP1514Z2UF	1.5 HP 2SP Motor	1
14	SP5700AM	Motor Housing	1
15	SP2700Z3	Screw	4
16	SP5700C	End Bell	1
17	SP1500T2	Screw	2
18	EC1325R	Swtch	1
19	SP1550WA5C	Cord Set	1
20	SP5700G	Motor Support	1
21	SP5700H	Main Base	1
22	SP2700Z2	Housing Square Nut	2
23	SP5700Z4	Bolt	2
24	SP5700Z5	Washer	2

OPTIONAL ELECTRONIC TIMER MODULE INSTRUCTIONS

Your integrated timer module is designed to be programmed to your filtration need, with four (4) possible settings.

TO SET TIMER

1. Move switch "OFF" to "PROGRAM" back to "OFF" - resulting single tone indicates Setting #1. Repeat until number of tones heard equals setting desired. ie 3 rapid tones is Setting #3
2. Move switch from "OFF" to "RUN: to begin selected program setting.

TWO SPEED MOTOR SETTINGS

- Setting 1 - Pump runs 24 hours on Hi Speed (single tone)
Setting 2 - Pump runs 18 hours on Hi, 6 hours on Low (2 tones)
Setting 3 - Pump runs 12 hours on Hi, 12 hours on Low (3 tones)
Setting 4 - Pump runs 6 hours on Hi, 18 hours on Low (4 tones)

SINGLE SPEED MOTOR SETTINGS

- Setting 1 - Pump runs 24 hours Continuous (single tone)
Setting 2 - Pump runs 18 hours, off 6 hours (2 tones)
Setting 3 - Pump runs 12 hours, off 12 hours (3 tones)
Setting 4 - Pump runs 6 hours, off 18 hours (4 tones)

TO OVERRIDE TIMER SETTINGS

Move switch from "RUN" to "OFF" and back to "RUN" within 3 seconds. The pump will run for 1 hour and then return to the previous programmed setting.
If a power failure occurs the timer automatically returns to the programmed setting.

SHAFT SEAL CHANGE INSTRUCTIONS

IMPORTANT SAFETY INSTRUCTIONS PLEASE READ AND FOLLOW ALL INSTRUCTIONS

When servicing electrical equipment, basic safety precautions should always be observed including the following. Failure to follow instructions may result in injury.

- A. ⚠ WARNING** - To reduce the risk of injury, do not permit children to use this product.
- B.** Disconnect all electrical power service to pump before beginning shaft seal replacement.
- C.** Only qualified personnel should attempt rotary seal replacement. Contact your local authorized Hayward Dealer or service center if you have any questions.
- D.** The National Electrical Code requires either a three (3) foot maximum twist-lock cord set with a GFCI protected receptacle or hard wire (conduit) connection for swimming pool pump installation. Do not use extension cords.

SAVE THESE INSTRUCTIONS

Exercise extreme care in handling both the rotating and stationary sections of the two-part replacement seal. Foreign matter or improper handling will easily scratch the graphite and ceramic sealing surfaces.

1. Shut off water flow to pump by closing appropriate valves or by plugging both the skimmer outlet port and return port to pool. Disconnect piping or hoses from the motor/pump assembly.
2. Remove 2 endbell cover screws and remove endbell cover. Remove white and red leads. Remove ground screw and ground wire(green).
3. Remove front base bolt and washer located on the underside of the pump. Remove front base attachment.
4. Remove the 4 motor cover screws and slide off motor cover.
5. Remove the 6 strainer cover housing screws and remove strainer housing.
6. Remove the 2 diffuser screws and diffuser.
7. Hold the motor shaft securely by either inserting a screwdriver in slot at end of shaft or by using an open-end wrench to engage the flat surfaces provided near end of motor shaft. Rotate the impeller in a counterclockwise direction and remove it from motor shaft.
8. Note how the steel spring section of the old seal is positioned on impeller hub and remove it by pulling from the impeller.
9. Loosen the 4 motor through bolts from the back of motor and remove pump motor plate.
10. Remove the ceramic stationary portion of the old seal by pressing the white ceramic seat out of the pump housing recess. If assembly is right, tap lightly from the "motor" side.
11. Clean and lubricate the impeller stem and the pump housing recess with a dilute solution of non-granulated liquid-type soap. Do not use petroleum or silicone lubricants as these can contribute to seal leakage.
12. Press the new rotating portion of the seal assembly onto the impeller stem with the polished black graphite surface facing away from the impeller.
13. Carefully press the stationary ceramic portion of the seal into the recess of the pump shroud, with the polished flat surface facing out.
14. Carefully insert the motor shaft through the pump motor plate and align with white ceramic stationary seal assembly in place and secure the four motor through bolts removed in step # 9. Be sure pump motor plate is positioned properly. Alternately tighten the motor through bolts until the motor plate is secure. Make certain motor shaft turns freely before proceeding.
15. Screw the impeller (clockwise) with the rotating portion of seal in place onto the motor shaft. Hand-tighten the impeller in place.
16. Clean (replace if necessary) the O-ring. Assemble the strainer assembly to the motor plate using the 6 screws removed in step # 5. Tighten screws alternately and evenly.
17. Re-assemble motor cover by sliding on cover and installing 4 screws removed in Step # 4.
18. Replace front base attachment and screw in nut and washer removed in Step # 3.
19. Reconnect wire leads from endbell assembly. White lead on L2 and red lead on L1. Replace ground wire and screw removed in Step # 2. Ensure leads and ground screw are firmly attached.
20. Align endbell cover with the two inside motor bosses and tighten endbell cover screws.
21. Reconnect pump into the piping or hoses provided. Open all valves and make sure that the pump strainer housing is full of water before restarting the pump.

ELECTRICAL GUIDE – 60 CYCLE MOTORS – SINGLE PHASE

MOTOR		VOLTS	Circuit Breaker RATING - AMPS	RECOMMENDED WIRE SIZE 0-50', 0-15m
HP	KW			
1	.75	115	20	No. 12
1 1/2	1.12	115	20	No. 12

TROUBLE SHOOTING GUIDE

A. MOTOR WON'T START

1. Check for improper or loose connections, open switches or relays, blown circuit breakers or fuses.
2. Manually check rotation of motor shaft for free movement and lack of obstruction.

B. MOTOR CUTS OUT – Check for:

1. Wiring, loose connections, etc.
2. Low voltage at motor (frequently caused by undersized wiring).
3. Binding and overload. (Amperage reading)

NOTE: Your Hayward pump motor is equipped with Automatic Thermal Overload Protection. The motor will automatically shut off, under normal conditions, before heat damage build-up, due to an improper operating condition, can occur. The motor will auto-restart when safe heat level is reached.

C. MOTOR HUMS BUT DOES NOT START

– Check for:

1. Centrifugal switch stuck in open position.
2. Binding of motor shaft.

D. PUMP WON'T PRIME

1. Make sure pump/strainer housing is filled with water, and that cover O-Ring is clean and properly seated. Make sure strainer cover is locked firmly in position.
2. Make sure all suction and discharge valves are open and unobstructed, and that pool water level is above all suction openings.

3. If pump develops a vacuum, check for blocked suction line or strainer, or air leak in suction piping.
4. If pump does not develop a vacuum and pump has sufficient "priming water":
 - a. Tighten all bolts and fittings.
 - b. Check voltage to make sure pump is up to speed.
 - c. Open pump and check for clogging and obstruction.
 - d. Remove and replace shaft seal.

E. LOW FLOW – Generally, Check for:

1. Clogged or restricted strainer or suction line; undersized pool piping.
2. Plugged or restricted discharge line of filter (high discharge gauge reading).
3. Air leak in suction (bubbles issuing from return fittings).
4. Pump operating underspeed (low voltage).
5. Plugged or restricted impeller.

F. NOISY PUMP – Check for:

1. Air leak in suction causing rumbling in pump.
2. Cavitation due to restricted or undersized suction line and unrestricted discharge lines. Correct suction condition or throttle discharge lines, if practical.
3. Vibration due to improper mounting, etc.
4. Foreign matter in pump housing.
5. Motor bearings made unserviceable by wear, rust, or continual overheating.

SERVICE AND REPAIRS

Consult your local authorized Hayward dealer or service center.
No pumps or motors may be returned directly to the factory without the express written authorization of Hayward Pool Products Canada, Inc.