

# OptiFlo® Plastic Pump for Aboveground Pools

## Installation, Operation & Service Manual



*PUMP IS DESIGNED AND INTENDED FOR USE TO CIRCULATE  
WATER IN ABOVEGROUND SWIMMING POOLS.*

### **WARNING**

This manual contains important safety instructions which must be furnished to the end user. Failure to read and follow instructions could result in serious personal injury and/or major property damage.

**IMPORTANT SAFETY INSTRUCTIONS  
READ AND FOLLOW ALL INSTRUCTIONS  
SAVE THESE INSTRUCTIONS**

#### ***Pentair Water Pool and Spa, Inc.***

1620 Hawkins Ave., Sanford, NC 27330 • 800-831-7133 or (919) 566-8000  
10951 West Los Angeles Ave., Moorpark, CA 93021 • 800-831-7133 or (805) 553-5000  
Visit us on the Internet at: [www.pentairpool.com](http://www.pentairpool.com) or [www.staritepool.com](http://www.staritepool.com)



# OptiFlo® Engineered Plastic Pump Installation, Operation & Service Manual

## Table of Contents

SECTION I.	HOW YOUR PUMP WORKS .....	3
SECTION II.	INSTALLATION .....	3-6
SECTION III.	PUMP OPERATION AND MAINTENANCE .....	6
SECTION IV.	SEAL REPLACEMENT PROCEDURE .....	6-7
SECTION V.	WINTERIZING PROCEDURE .....	7
SECTION VI.	TROUBLESHOOTING GUIDE .....	8
SECTION VII.	TECHNICAL DATA .....	9-12

### **WARNING**

To reduce the risk of injury, do not permit children to use this product unless they are closely supervised at all times.

### **WARNING**

Before installing this product, read and follow all warning notices and instructions accompanying this pump. Failure to follow safety warnings and instructions can result in severe injury, death, or property damage. Call (800) 831-7133 for additional free copies of these instructions.

### **Important Notice**



Attention Installer.

This manual contains important information about the installation, operation and safe use of this product. This information should be given to the owner/operator of this equipment.

### **PUMPSAFETYINSTRUCTIONS**

When installing and using this electrical equipment, basic safety precautions should always be followed, including the following:

### **WARNING**



#### **RISK OF ELECTRICAL SHOCK OR ELECTROCUTION**

This pool pump must be installed by a licensed or certified electrician or a qualified pool serviceman in accordance with the National Electrical Code and all applicable local codes and ordinances. Improper installation will create an electrical hazard which could result in death or serious injury to pool users, installers, or others due to electrical shock, and may also cause damage to property.

Always disconnect power to the pool pump at the circuit breaker before servicing the pump. Failure to do so could result in death or serious injury to serviceman, pool users or others due to electric shock.

### **WARNING**

Risk of Electrical Shock. Connect only to a grounding type receptacle protected by a ground-fault circuit-interrupter (GFCI). Contact a qualified electrician if you cannot verify that the receptacle is protected by a GFCI.

### **WARNING**

Do not bury the electrical cord. Locate the cord to minimize the abuse from lawn mowers, hedge trimmers, and other equipment.

### **WARNING**

To reduce the risk of electrical shock, replace damaged cord immediately.

 **WARNING**

To reduce the risk of electrical shock, do not use an extension cord to connect unit to electric supply; provide a properly located outlet.

 **WARNING**

For continued protection against possible electrical shock, this unit is to be mounted to the base in accordance with the installation instructions.

**Important Notice**

This pump operates with electrical voltage, and can generate both vacuum and pressure in the water system. When properly wired and plumbed, this pump will operate in a safe manner.

 **CAUTION**

This pump is for use with permanently installed pools and may also be used with hot tubs and spas. Do not use with storable pools unless pump is protected by factory installed double insulated enclosure. A permanently installed pool is constructed in or on the ground or in a building such that it cannot be readily disassembled for storage. A storable pool is constructed so that it may be readily disassembled for storage and reassembled to its original integrity and has a maximum dimension of 18 feet and a maximum wall height of 42 inches.

**READ AND FOLLOW ALL SAFETY INSTRUCTIONS**

**SECTION I. HOW YOUR PUMP WORKS**

Your centrifugal pump is designed to operate for years with proper maintenance. The pump housing, seal plate, hair and lint pot and impeller are made from high quality thermoplastic materials. These materials have been selected for their corrosion resistance nature. When installed, operated and maintained in accordance with these instructions, your pump will provide years of service.

Your centrifugal pump is driven by an electric motor. The motor is directly attached to the pump impeller. As the electric motor turns it causes the impeller to turn and this causes the water to flow. The water flows into the hair and lint pot inlet and through the basket assembly to pre-strain large particles. The flow then enters the center of the pump housing. If the pump does not contain the hair and lint pot assembly, the flow simply enters the center of the pump housing. The flow goes through the impeller and out the pump discharge port.

**2-Speed Pump Models:**

The performance of this pump will be the same at high speed as the same model single speed pump, hydraulically. At low speed the pump will produce one half the flow and 1/4 the pressure of high speed. However, the pressure required by the filter and pool plumbing at half flow will also be greatly reduced due to much lower system friction. These lower friction losses result in GREAT energy savings. At one half flow (low speed) the electrical energy savings are 60% for equal amounts of circulated water.

Turn the motor to low speed for quiet operation and electrical cost savings. Since the pump should be operated mostly at low speed for cost savings, minor adjustments may be required in the automatic chlorine dispenser, the skimmers and the heater due to the lower flow. (See the equipment manufacturer's operation manuals.)

Pool owners should use high speed for vacuuming the pool, quick filtering action, priming the system, and to keep up with heavy bathing loads.

**SECTION II. INSTALLATION**

1. Check carton for any evidence of damage due to rough handling in shipment. If carton or any pump components are damaged, notify freight carrier immediately.
2. After inspection, carefully remove pump from carton.
3. The pump should be secured to a flat solid foundation, high enough to prevent flooding of the motor. A sheltered location is best, being sure to allow for adequate ventilation.

4. Provide space and lighting for routine maintenance access. Do not mount electrical controls directly over pump.
5. The pump should be installed as near to the pool or spa as practical. Avoid installing the pump **above the water level**. Suction lifts of more than 1/2 foot will cause very long priming times, and potentially damage the pump.
6. The location should provide for adequate floor drainage to prevent flooding.
7. When installing your pump, remember to provide valves or other means to disconnect the pump suction and discharge for servicing.
8. Never store pool chemicals within 10 ft. of your pool filter and pump. Pool chemicals are corrosive and should always be stored in a cool, dry, well ventilated area.

 **WARNING**

Chemical fumes and/or spills can cause severe corrosive attack to the filter and pump structural components. Structurally weakened filter or pump components can cause filter, pump or valve attachments to blow off and could cause severe bodily injury or property damage.

9. Assemble piping and pipe fittings to pump and valve. All piping must conform to local and state plumbing and sanitary codes.
10. Use Teflon tape or pipe sealants on all male connections of pipe and fittings. Use only pipe sealant compounds suited for plastic pipe. Support pipe to prevent strains on filter, pump or valve. **DO NOT USE PETROLEUM BASED PRODUCTS.**
11. Avoid over tightening the pipe threads when connecting fittings to the pump. Proper procedure is to apply a pipe sealant to the thread and then install hand tight plus 1 1/2 turns. **DO NOT OVER TIGHTEN.**
12. Long piping runs and elbows restrict flow. For best efficiency use the fewest possible fittings, large diameter pipe (at least 1 1/2") & locate equipment as close to the pool as possible. The pump suction line should not be smaller than the pipe size on the inlet of the pump.
13. It is essential that the suction line be free of air leaks and air traps.

 **WARNING**

Blockage of suction fittings can cause severe or fatal injury due to drowning. Small children using pool/spa equipment must always have close adult supervision.

14. Suction fittings must conform to ASME/ANSI A 112.19.8 M Standards. Use double suction fittings.
15. The maximum operating pressure of this unit is 25 pounds per square inch. Never operate this pump above this pressure.

This pump is not intended to be operated in series with other pumps.

 **WARNING**

To reduce the risk of injury, do not permit children to use this product unless they are closely supervised at all times.

16. Wiring of this pump should be performed by a licensed electrician in accordance with the National Electrical Code or your local electrical code.

 **WARNING**

Never work on pump while it is running or power is still connected; hazardous voltage can cause severe or fatal injury. A suitable ground fault interrupter should always be installed at the power supply source of this unit.

17. The pump motor must be wired for the proper voltage in accordance with the wiring diagram supplied with the motor. Wiring the motor with the incorrect supply voltage will cause damage to the motor and void the warranty.
18. The wiring to the motor should be kept as short as possible and large enough NOT to cause an excessive voltage drop. Use the wire size table as a guide in selecting minimum conductor size.

RECOMMENDED CIRCUIT BREAKER AND WIRING DATA					
MOTOR HP	BRANCH CIRCUIT	VOLTS Hz/PHASE	DIST. IN FT. OF BRANCH CIRCUIT		MIN. SERVICE WIRE SIZE TO MOTOR
			0-50 FT.	50-100 FT.	
3/4	15 A	115/60/1	#14	#14	
1	15 A	115/60/1	#12	#12	
1-1/2	20 A	115/60/1	#12	#10	
1-1/2	15 A	230/60/1	#14	#14	

19. Install, ground and bond wire according to local or National Electrical Code requirements.

**GROUNDING**

20. Permanently ground motor. Use green terminal provided under motor canopy or access plate; use size and type wire required by code. Connect motor ground terminal to electrical service ground. On cord connected circuits, check for proper grounding.

**BONDING - (for permanently wired pumps)**

21. The National Electrical Code Article 680-22 requires that the motor be electrically bonded to appropriate permanently installed pool or spa/hot tub structure by a solid copper conductor no smaller than No. 8 AWG. Bonding wire should be connected from the accessible wire connector on the motor shell to all metal parts of the swimming pool, spa or hot tub structure and to all electrical equipment, metal conduit and metal piping within 5 feet of the inside walls of a swimming pool, spa or hot tub. A grounding lug is provided on the exterior of the motor shell for this purpose.

 <b>WARNING</b>
(For cord and plug-connected units) Do not bury cord. Locate cord to minimize abuse from lawn mowers, hedge trimmers and other equipment.

 <b>WARNING</b>
(For cord and plug-connected units) To reduce the risk of electric shock, replaced damaged cord immediately.

 <b>WARNING</b>
(For cord and plug-connected units) To reduce the risk of electric shock, do not use extension cord to connect unit to electric supply; provide a properly located outlet.

 <b>CAUTION</b>
Do not install within an outer enclosure or beneath the skirt of a hot tub or spa unless so marked.

## INITIAL START-UP:

1. Relieve all system pressure and open all air bleeders on total hydraulic system prior to starting the pump. See filter owner's manual.
2. Ensure that all fittings, clamps, closures and couplings are tight and in accordance with equipment manufacturer's recommendations.
3. Open suction and discharge valving to allow free flow of water. On flooded suction pumps with strainer pot the water source is higher than the pump. The water will flow into the pump strainer pot and the pot will fill with water. On pumps without strainer pot the water will fill the pump housing.
4. On non-flooded suction systems the pot lid clamp will have to be removed by rotating the lid counter-clockwise to a stop and lifting the clamp.
5. The pump strainer pot should be filled with water up to suction opening on the pump.
6. It is good practice to lubricate the lid o-ring with silicone lubricant each time the lid is removed. The o-ring should be cleaned and inspected every time the strainer pot is opened.
7. The lid should be replaced on the pot by aligning the clamp ears with the slots on the strainer pot. Press the lid and clamp down and twist the clamp clockwise to engage.
8. The pump is now ready to prime. Turn the motor on and the pump will prime. The time to prime will depend on the suction lift and the distance and size of suction piping. Turn off power if the pump does not prime within five minutes and refer to the Troubleshooting Guide section of this manual.

---

### NOTICE

Never run the pump dry. Running the pump dry may damage the seals and pump housing. This could allow water leakage and flooding.

---

## SECTION III. PUMP OPERATION AND MAINTENANCE

 <b>WARNING</b>
----------------------------------------------------------------------------------------------------

DO NOT open the strainer pot if pump fails to prime or if pump has been operating without water in the strainer pot. Pumps operated in these circumstances may experience a build up of vapor pressure and may contain scalding hot water. Opening the pump may cause serious personal injury. In order to avoid the possibility of personal injury, make sure the suction and discharge valves are open and strainer pot temperature is cool to touch, then open with extreme caution.
-----------------------------------------------------------------------------------------------------------------------------------------------------------------------------------------------------------------------------------------------------------------------------------------------------------------------------------------------------------------------------------------------------------------------------------------------------------------------------------------

The strainer basket in the pump should be inspected and cleaned twice each week. Remove the clear lid and the basket, and clean debris from basket. Inspect the lid o-ring; if damaged, replace. The pump seal requires no lubrication. Refer to motor service centers for motor servicing.

## SECTION IV. DISASSEMBLY/ASSEMBLY PROCEDURE FOR SEAL REPLACEMENT

 <b>WARNING</b>
----------------------------------------------------------------------------------------------------

Never work on pump while it is running or power is still connected. Hazardous voltage can cause severe or fatal injury.
-------------------------------------------------------------------------------------------------------------------------

1. Stop pump and relieve system pressure.
2. Disconnect motor power at Circuit Breaker.
3. Close suction and discharge valves.

4. Use extreme care when handling the mechanical seal. The mating seal surfaces are polished and are easily damaged.
5. The mechanical seal can be changed without disconnecting piping by removing 4 bolts (see item 14 on page 9) and pulling the motor with pump seal plate and impeller assembly away from front pump housing body.
6. Remove impeller and rotating portion of seal by holding motor shaft and rotating the impeller counter-clockwise when facing the shaft extension on the motor.
7. The rotating portion of the seal can now be removed from the impeller. Clean the impeller hub and lubricate with soapy water. Wipe off shining carbon sealing surface of new mechanical seal with a clean tissue to remove oily fingerprints or other foreign materials. The new rotating seal can be pressed back onto the impeller.
8. To remove the stationary ceramic seal seat, first loosen the four motor bolts which run through the entire length of the motor into the seal plate. Remove the seal plate from the motor. Press the ceramic seat and rubber gasket out of the seal plate.
9. Clean the seal plate seal area and lubricate with soapy water. Press the new ceramic seal and gasket into the seal plate, being sure it is fully seated. Wipe off the ceramic sealing surface with a clean tissue to remove oily fingerprints or foreign substances.
10. Place the seal plate on the motor and carefully align the four motor through bolts. Secure the seal plate onto the motor being careful not to overtighten the bolts. Gradually bring bolts up to final tightness by moving across in a criss-cross pattern.
11. Check the position of the mechanical seal set in the seal plate and ensure the motor shaft is in the center of the seal set.
12. Screw the impeller with new rotating seal onto the motor shaft. Rotate the motor shaft to make sure the impeller is not touching the seal plate.
13. Clean the seal plate "O" Ring and check to make sure it is in position. Replace the motor and seal plate on the front pump housing body and bolt into position with 4 bolts. Gradually bring bolts up to final tightness by moving across in a criss-cross pattern.
14. Refer to initial start-up procedures to restart the pump.

## **SECTION V. WINTERIZING PROCEDURE**

---

### **NOTICE**

Allowing the water to freeze in pump will damage the pump and cause potential water damage/flooding and potential property damage.

---

1. Drain all water from pump housing and piping when freezing temperatures are expected. A drain plug is provided to drain the pump. If the pump has a strainer pot both the strainer drain plug and the housing drain plug should be removed. If pump has no strainer pot then only remove the housing plug.
2. If the pump can be removed and placed in an inside dry location this should be done.
3. For an outdoor unprotected location it is best to protect the equipment in a weatherproof enclosure.
4. Do not wrap the motor with plastic because condensation could form inside the motor.
5. In installation where the pump cannot be drained a 40% propylene glycol 60% water solution will protect to -50° F.

---

### **NOTICE**

Do not use anti-freeze solutions except propylene glycol, as other anti-freeze is highly toxic and will damage the pump.

---

## SECTION VI. TROUBLESHOOTING GUIDE

The following are some common causes of problems that may arise.

<b>PROBLEM</b>	<b>CAUSE</b>	<b>REMEDY</b>
Pump will not prime.	No water in strainer pot.	Add water to pot.
	Strainer pot lid is not tight.	Tighten lid.
	Damaged lid o-ring.	Replace o-ring.
	Water level is below skimmer.	Adjust pool water level.
	Strainer basket or skimmer basket is clogged.	Clear basket.
	Closed valve in piping system.	Check all valves and open all necessary valves.
	Pump is on low speed (two-speed units only).	Adjust to high speed.
	Air leak in suction line.	Find and fix leak.
	Water level is too low and the pump cannot lift.	Adjust pump level and insure it is below water level.
Low flow — high filter pressure.	Filter is dirty.	Clean filter.
	Restriction in return line.	Open return line restriction.
Low flow — low filter pressure.	Strainer basket or skimmer basket clogged.	Clean basket.
	Clogged impeller.	Clean obstruction.
	Air leak in suction line.	Find and fix leak.
	Restriction in suction line.	Find and open restriction.
Motor does not turn.	Power switch is off.	Check power switch and reset.
	Circuit breaker has tripped.	Check circuit breaker and reset; if retrips contact electrician.
	Pump is in off-mode of a timer controlled circuit.	Check timer mode.
	Motor terminal connections are incorrect.	Have terminal connections checked by electrician.
	Motor shaft is locked by bad bearing.	Have motor bearings replaced or replace pump.
Motor over-heating.	Electrical supply connections are incorrect.	Have terminal connections checked by electrician.
	Wiring to pump is undersized.	Consult electrician to rewire pump.
	Power Company supply voltage is low.	Notify Power Company.
	Ventilation is inadequate for motor.	Remove any restrictions to air flow.



## SECTION VII. TECHNICAL DATA

### REPLACEMENT PARTS

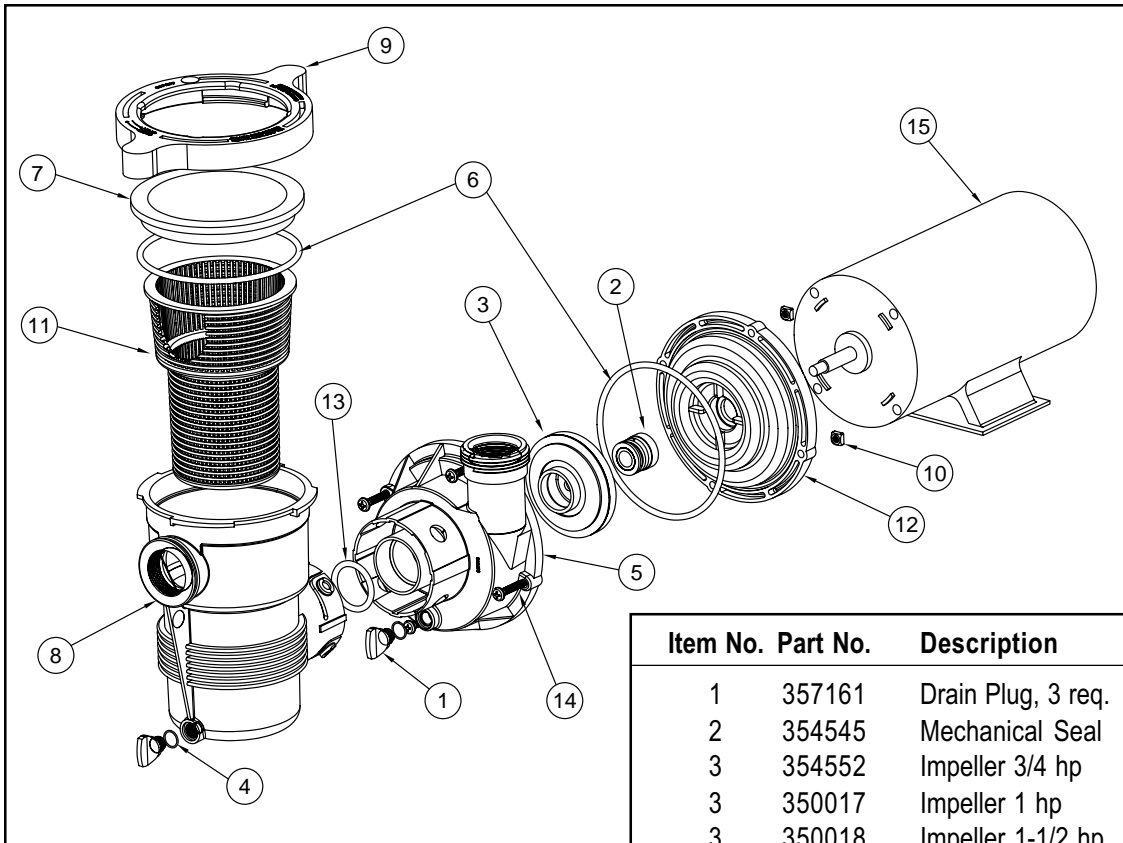

Item No.	Part No.	Description
1	357161	Drain Plug, 3 req.
2	354545	Mechanical Seal
3	354552	Impeller 3/4 hp
3	350017	Impeller 1 hp
3	350018	Impeller 1-1/2 hp
4	192115	O-ring, 3 req.
5	357213	Volute & Pot Assembly HD
6	357255	O-ring 2-357, 2 req.
7	357227	Lid
8	357228	Pot & Volute Assembly VD
9	357239	Clamp Ram & Cam
10	357254	1/4-20 Square Nut, 4 req.
11	355667	Basket
12	357215	Seal Plate
13	350103	O-ring
14	98209000	1/4-20 x 1.5 Machine Screw, 4 req.
15		Motor(s)
	356597	Motor TB 3 /4 hp-1ph-60hz-115V, w/switch
	356595	Motor TB 1 hp-60hz-115V, w/switch
	356469	Motor TB 1.5 hp-60hz-230V/115V, wo/switch
	356551	Motor TB 1 hp-60hz-115V - 2 spd
	356553	Motor TB 1.5 hp-60hz - 2 spd
	356436	Motor TB 3/4 hp-60hz-115V, wo/switch
	356437	Motor TB 1 hp-60hz-115V, wo/switch
	356440	Motor TB 1.5 hp-60hz-115V/230V
	39604323	Motor 3/4 hp-48FR-230V-60hz
	39604423	Motor 1 hp-48FR-230V-60hz
	39607600	Motor 1.5 hp-48FR-230V-60hz
	354170	Motor 3/4 hp-230V-50hz
	354573	Motor 1 hp-230V-50hz
	39604508	Motor 1.5 hp-48FR-230V-50hz

## REPLACEMENT PARTS (BASE MOUNTED UNITS)

For cord and plug connected units, the base should be mounted as shown.

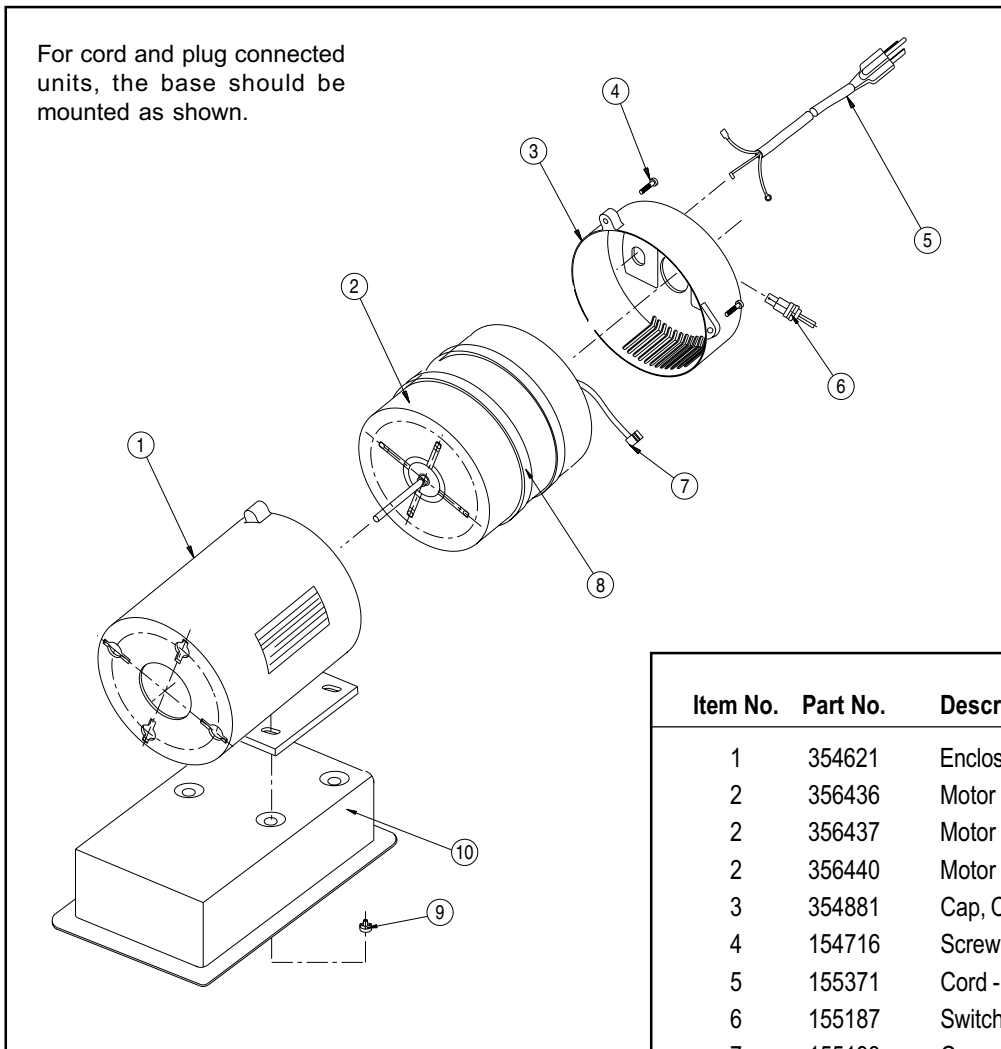

Item No.	Part No.	Description
1	354621	Enclosure Housing
2	356436	Motor 3/4 hp, 48 Frame
2	356437	Motor 1 hp, 48 Frame
2	356440	Motor 1-1/2 hp, 48 Frame
3	354881	Cap, CSA Mtr. Enclsr. w/3 Screws
4	154716	Screw - Self Tapping HH #10, 3 req.
5	155371	Cord - 25 ft. 16 Ga. Power Supply
6	155187	Switch Toggle Double Insulated
7	155193	Conn. #16 Switch
8	354658	Insulated Foam w/Adhsve. Back
9	155109	Nut - T4 Prong
10	153263	Base CSA 4 in. High

## DIMENSIONAL DATA

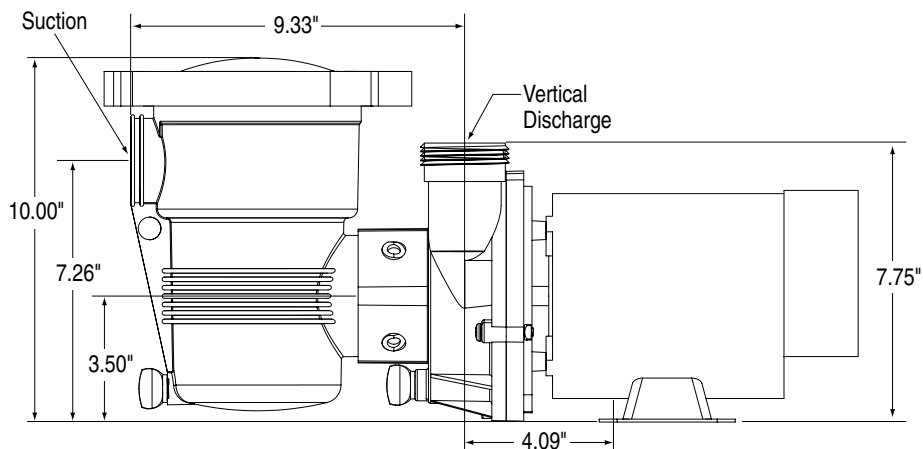

# PUMP CURVES

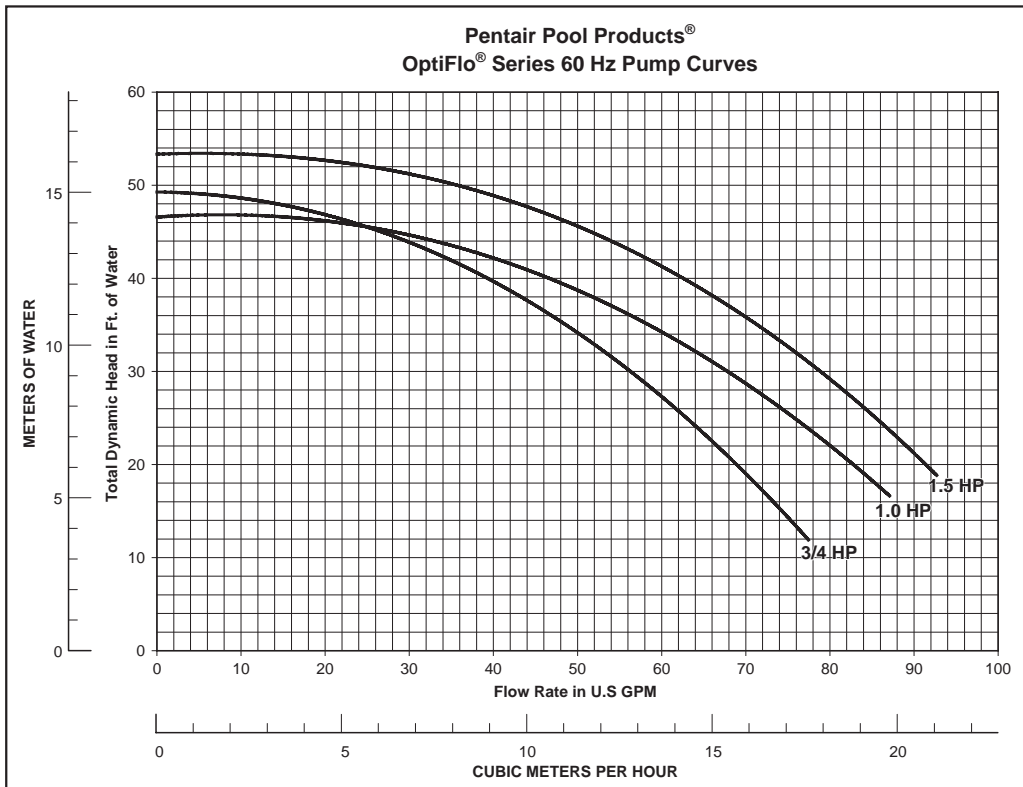
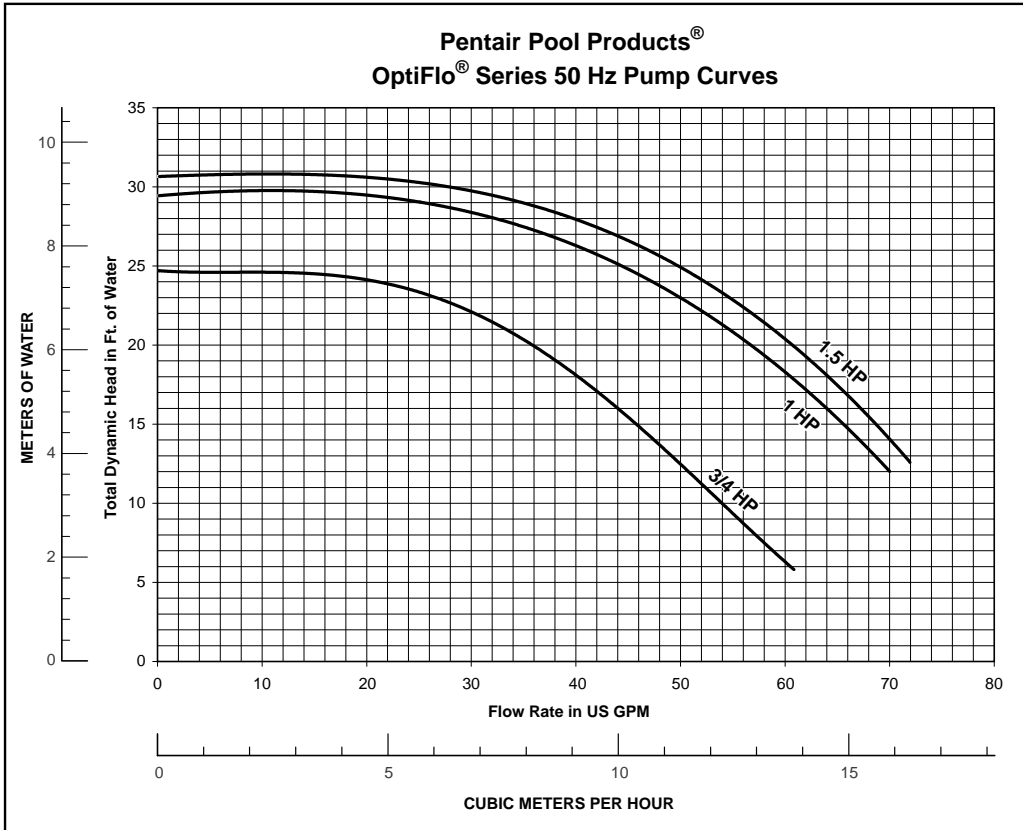

## ENGINEERING SPECIFICATIONS

60 Hz OptiFlo Pumps							
S. No.	Pump P/N	Description	Model Name/Number	Volts	Amps	Wt.	Cord Length
1	347981	PMP OPTFL N1 3/4HP HD 3' STD ①	OPT-N1-3/4HP-HD - 3' STD	115	9.8	20	3' STD
2	347984	PMP OPTFL N1 3/4HP VD 3' STD ①	OPT-N1-3/4HP-VD - 3' STD	115	9.8	20	3' STD
3	347982	PMP OPTFL N1 1HP HD 3' STD ①	OPT-N1-1HP-HD - 3' STD	115	12	22	3' STD
4	347985	PMP OPTFL N1 1HP VD 3' STD ①	OPT-N1-1HP-VD - 3' STD	115	12	22	3' STD
5	347983	PMP OPTFL N1 1.5HP HD 3' STD ①	OPT-N1-1.5HP-HD - 3' STD	230/115	8/16	24	3' STD
6	347986	PMP OPTFL N1 1.5HP VD 3' STD ①	OPT-N1-1.5HP-VD - 3' STD	230/115	8/16	24	3' STD
7	347991	PMP OPTFL N2 1HP HD 3' STD ①	OPT-N2-1HP-HD - 3' STD	115	11/2.9	22	3' STD
8	347990	PMP OPTFL N2 1HP VD 3' STD ①	OPT-N2-1HP-VD - 3' STD	115	11/2.9	22	3' STD
9	340079	PMP OPTFL N2 1.5HP HD 3' STD ①	OPT-N2-1.5HP-HD - 3' STD	115	16.4/4.4	24	3' STD
10	347992	PMP OPTFL N2 1.5HP VD 3' STD ①	OPT-N2-1.5HP-VD - 3' STD	115	16.4/14.4	24	3' STD
11	340066	PMP OPTFL N1 3/4HP HD 3' TWL ①	OPT-N1-3/4HP-HD - 3' TWL	115	9.8	20	3' TWL
12	340065	PMP OPTFL N1 3/4HP VD 3' TWL ①	OPT-N1-3/4HP-VD - 3' TWL	115	9.8	20	3' TWL
13	347988	PMP OPTFL N1 1HP HD 3' TWL ①	OPT-N1-1HP-HD - 3' TWL	115	12	22	3' TWL
14	347987	PMP OPTFL N1 1HP VD 3' TWL ①	OPT-N1-1HP-VD - 3' TWL	115	12	22	3' TWL
15	347989	PMP OPTFL N1 1.5HP HD 3' TWL ①	OPT-N1-1.5HP-HD - 3' TWL	230/115	8/16	24	3' TWL
16	340067	PMP OPTFL N1 1.5HP VD 3' TWL ①	OPT-N1-1.5HP-VD - 3' TWL	230/115	8/16	24	3' TWL
17	340071	PMP OPTFL N2 1HP HD 3' TWL ①	OPT-N2-1HP-HD - 3' TWL	115	11/2.9	22	3' TWL
18	340070	PMP OPTFL N2 1HP VD 3' TWL ①	OPT-N2-1HP-VD - 3' TWL	115	11/2.9	22	3' TWL
19	340073	PMP OPTFL N2 1.5HP HD 3' TWL ①	OPT-N2-1.5HP-HD - 3' TWL	115	16.4/4.4	24	3' TWL
20	340072	PMP OPTFL N2 1.5HP VD 3' TWL ①	OPT-N2-1.5HP-VD - 3' TWL	115	16.4/14.4	24	3' TWL
21	347993	PMP OPTFL N1 3/4HP HD 25' STD STORABLE POOL ②	OPT-N1-3/4HP-HD - 25' STD	115	9.8	20	25' STD
22	347996	PMP OPTFL N1 3/4HP VD 25' STD STORABLE POOL ②	OPT-N1-3/4HP-VD - 25' STD	115	9.8	20	25' STD
23	347994	PMP OPTFL N1 1HP HD 25' STD STORABLE POOL ②	OPT-N1-1HP-HD - 25' STD	115	12	22	25' STD
24	347997	PMP OPTFL N1 1HP VD 25' STD STORABLE POOL ②	OPT-N1-1HP-VD - 25' STD	115	12	22	25' STD
25	347995	PMP OPTFL N1 1.5HP HD 25' STD STORABLE POOL ②	OPT-N1-1.5HP-HD - 25' STD	230/115	8/16	24	25' STD
26	347998	PMP OPTFL N1 1.5HP VD 25' STD STORABLE POOL ②	OPT-N1-1.5HP-VD - 25' STD	230/115	8/16	24	25' STD
27	340088	PMP OPTFL N1 3/4HP 230V 60HZ VD W/O CRD, SWITCH	OPT-N1-3/4HP-230V 60HZ VD	230	4.6	20	N/A
28	340089	PMP OPTFL N1 1HP 230V 60HZ VD W/O CRD, SWITCH	OPT-N1-1HP-230V 60HZ VD	230	6	22	N/A
29	340090	PMP OPTFL N1 1.5HP 230V 60HZ VD W/O CRD, SWITCH	OPT-N1-1.5HP-230V 60HZ VD	230	8/12.6	24	N/A
50 Hz OptiFlo Pumps							
30	340056	PMP OPTFL N1 3/4HP VD 230V 50HZ W/O CRD, SWITCH	OPT-N1-3/4HP 50HZ VD	220-240	4.8-5.0	20	N/A
31	340057	PMP OPTFL N1 1HP VD 230V 50HZ W/O CRD, SWITCH	OPT-N1-1HP 50HZ VD	220-240	6.0-6.2	22	N/A
32	340058	PMP OPTFL N1 1.5HP VD 230V 50HZ W/O CRD, SWITCH	OPT-N1-1.5HP 50HZ VD	220-240	7.2-7.8	24	N/A

N1--> Single Speed

N2--> Dual Speed (Two Speed)

HD--> Horizontal Discharge

VD--> Vertical Discharge

①--> UL and CUL Listed

②--> UL and CSA Listed

# SAVE THESE INSTRUCTIONS

© 2006 Pentair Water Pool and Spa, Inc. All rights reserved.

This document is subject to change without notice.

1620 Hawkins Ave., Sanford, NC 27330 • 800-831-7133 or (919) 566-8000

10951 West Los Angeles Ave., Moorpark, CA 93021 • 800-831-7133 or (805) 553-5000

**Trademarks and Disclaimers.** The *Pentair Pool Products logo* and OptiFlo are registered trademarks of Pentair Water Pool and Spa, Inc. Other trademarks and trade names may be used in this document to refer to either the entities claiming the marks and names or their products. Pentair Water Pool and Spa, Inc. disclaims any proprietary interest in trademarks and trade names other than its own.