

OWNER'S MANUAL



 **Polaris TurboTurtle**

IMPORTANT INFORMATION

Polaris Turbo Turtle

Important Information

The Polaris Vac-Sweep® Turbo Turtle™ automatic pool cleaner comes ready to connect to 1-1/2" female pipe threads on a return line. Other connections are possible, but require additional fittings (see Section B on page 3).

The following are important points to remember when installing and operating the Polaris Turbo Turtle.

- Always disconnect the Polaris from the pool wall when cleaning or backwashing the pool filter.
- After cleaning or backwashing, let the filtration system run for at least five minutes before reconnecting the Polaris.
- New plumbing lines should be flushed out before installing the Polaris.
- Always handle the Polaris with care. Do not let children play with it; it is not a toy.
- Never handle the Polaris when it is operating.
- Always remove the Polaris **before swimmers enter the pool.**
- Always remove the Polaris from the pool before chemical shock treatments. As a general rule, any pool water that is unsafe for swimming is unsafe for the Polaris.
- Carefully cut the float hose following the instructions on page 4.

By following these simple guidelines, you can help protect against injury and prolong the life of the Polaris Turbo Turtle.

When replacing any Polaris parts, always insist on genuine Polaris replacement parts. You can be sure you are buying genuine Polaris parts if they come in Polaris part bags or have the Polaris logo  on them. Non-Polaris parts are not made to our specifications. They may have an adverse effect on the operation of the Polaris or may even damage it. If you are unable to find genuine Polaris parts in your area, contact our Customer Service Department for the name of a local Polaris dealer nearest you.

Our Customer Service Department is available toll-free at 1-800-VAC-SWEEP (USA and Canada only) or (760) 599-9600, Monday through Thursday, 6:00 a.m. - 5:00 p.m., Friday, 6:00 a.m. - 3:00 p.m. (Saturdays 6:00 a.m. - 2:30 p.m. during summer months) PST.

Before installing the Polaris, please take a moment to record the serial number. For the location of the serial number, refer to the diagram in Section A on page 3. You will be asked for this number when contacting our Customer Service Department.

Serial # _____

WARNING: USE OF POLARIS TURBO TURTLE IN A VINYL LINER POOL

Certain vinyl liner patterns are particularly susceptible to rapid surface wear or pattern removal caused by a variety of objects coming into contact with the vinyl surface, including pool brushes, pool toys, floats, fountains, chlorine dispensers, and automatic pool cleaners. Some vinyl liner patterns can be seriously scratched or abraded simply by rubbing the surface with a pool brush. Ink from the pattern can also rub off during the installation process or when it comes into contact with objects in the pool. Polaris is not responsible for, and the Limited Warranty does not cover, pattern removal, abrasion or markings on a vinyl liner.

I. Introduction

Thank you for choosing a Polaris Turbo Turtle™. You will find that it vacuums the bottom and sweeps the sides of any size or shape above-ground pool. The Polaris Turbo Turtle does all the hard work for you, leaving you with a sparkling clean pool. It's simple to use and easy to install. Just follow these step-by-step instructions.

II. Installation Instructions

A. Polaris Turbo Turtle Components

The Polaris Turbo Turtle box contains:

1. Surface Module
2. Jet Sweep Assembly
3. All-Purpose Bag
4. Sweep Hose, 7 Ft.
5. Float Hose, 24 Ft.
6. Quick Disconnect
7. Universal Wall Fitting

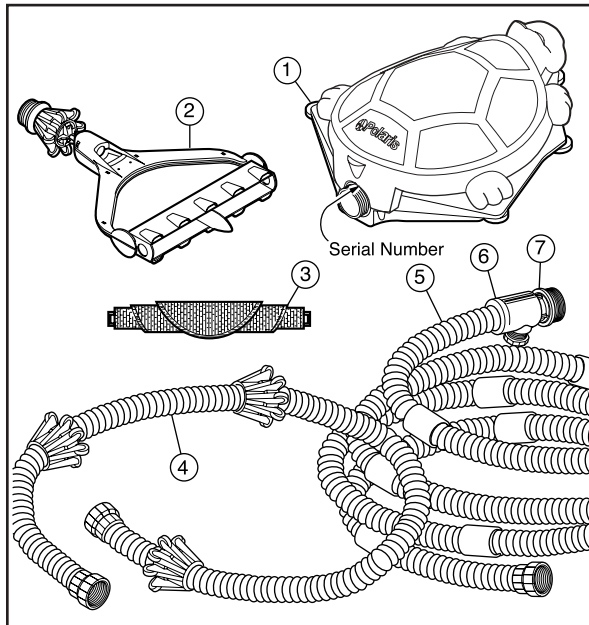

B. Installing the Universal Wall Fitting

It is important to have a clean pool filter before installing the Polaris Turbo Turtle.

1. Turn on the pool filtration pump and flush out the plumbing line. Turn off the pump.
2. Unscrew the universal wall fitting from the quick disconnect.

- If the return line has 1-1/2" female threads exposed, screw in the universal wall fitting by hand. Turn the quick disconnect clockwise (also by hand) into the universal wall fitting to tighten it into place; **do not over-tighten**. Once the universal wall fitting is secure, the quick disconnect can be removed without removing the universal wall fitting.
- If the return line looks like the one below, remove the parts shown and install the universal wall fitting as described above.

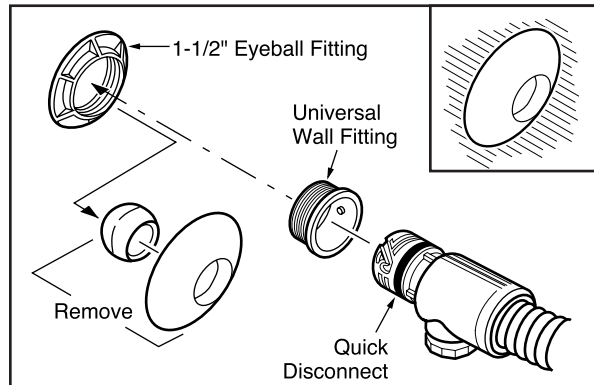

- If the return line looks like the one below, remove the parts shown and install the universal wall fitting as described above.

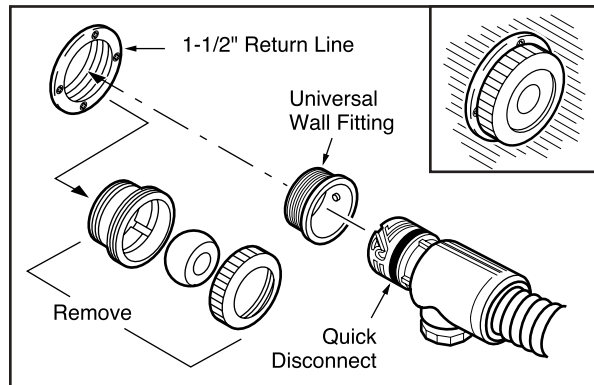

- If the return line is a 1-1/4" or 2" eyeball fitting, you will need to obtain a Polaris Adapter Kit (part #6-510-00) from a participating Polaris dealer.

If the return line is different than those listed, contact our Customer Service Department at 1-800-VAC-SWEEP.

Note: Once installed, verify the cleaner is operating according to the Operation Section on page 5.

C. Adjusting the Float Hose

1. With the pool filtration pump off, connect the float hose to the pool wall by turning the quick disconnect clockwise into the universal wall fitting. Pull away from the pool wall to secure.

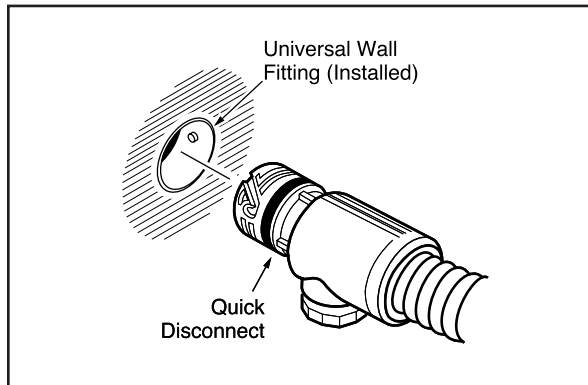

2. Extend the float hose to the farthest point in the pool.
3. Cut the float hose so it is four feet short of the farthest point of the pool.

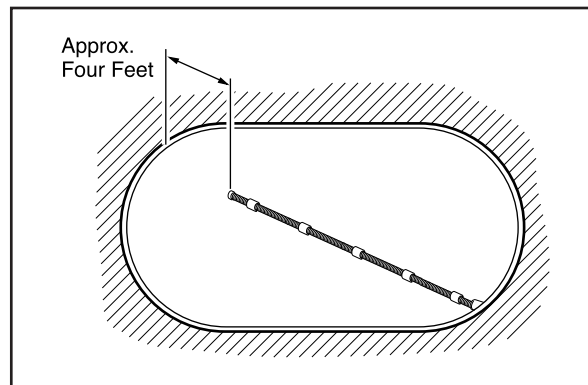

If the float hose does not come within four feet of the farthest point, you will need to add a float hose extension kit (part #6-221-00) available at a participating Polaris dealer.

4. Remove the hose connector from the portion of excess hose that was just removed and attach it to the new end of the float hose. See the diagram at the top of the next column.
5. Attach the sweep hose and the filter bag to the jet sweep assembly. When attaching the filter bag, make sure its frame is completely open.
6. Attach the float hose and the sweep hose to the surface module. When attaching the

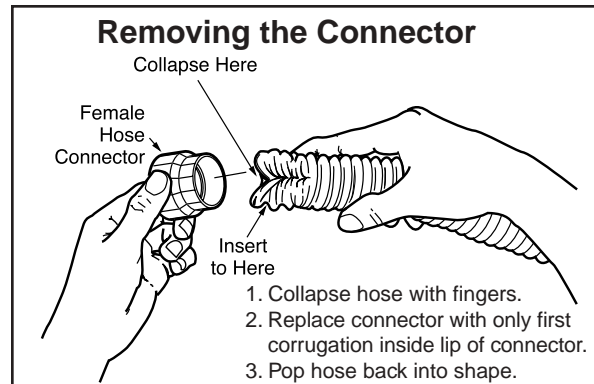

sweep hose, make sure the large ends of the wheel cages are pointing toward the filter bag.

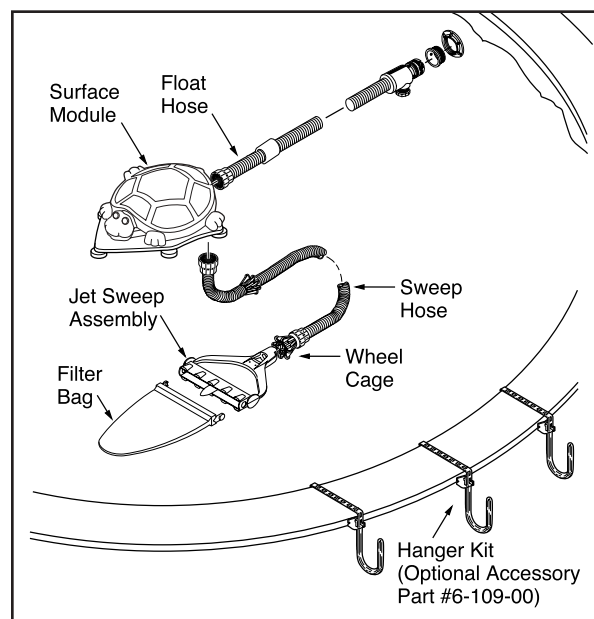

NOTE: The connectors twist independently of the hose. When attaching them, twist only the connectors so the hose does not get twisted.

7. Put the Polaris in the pool and turn on the pool pump. Extend the float hose back to the farthest point in the pool. The float hose is

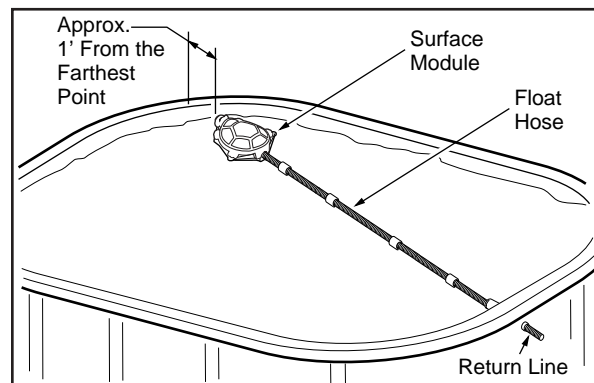

cut correctly if the surface module is approximately one foot from the pool wall when the pump is running.

D. Operation

When operating correctly, the surface module will float level on the pool surface. It will change directions approximately every 15-25 seconds. As the Polaris moves randomly throughout the pool, it recirculates clean, filtered water.

The filter bag should contact the pool floor a majority of the time collecting dirt and debris. It will remove debris as large as leaves or as fine as sand. The Polaris Turbo Turtle will vacuum and sweep the pool in three hours or less.

The Polaris comes equipped with an automatic pressure relief valve in the quick disconnect. If the Polaris is receiving too much water pressure, it will release water at the quick disconnect.

Observe the movement of the surface module to verify that the cleaner is not operating too fast. The cleaner is operating too fast if the sweep hose and bag are not in contact with the pool bottom a majority of the time and the surface module changes directions more frequently than every 15 to 25 seconds. In this case, unscrew the pressure relief valve until the surface module slows down. For further information, please refer to the Troubleshooting Section on page 6.

WARNING: IMPROPER OPERATION MAY RESULT IN DAMAGE TO THE CLEANER, POOL OR POOL EQUIPMENT.

III. Maintenance

To ensure the Polaris is operating at its optimal efficiency, it is important to empty the filter bag and clean the filter screen on a regular basis. It is also

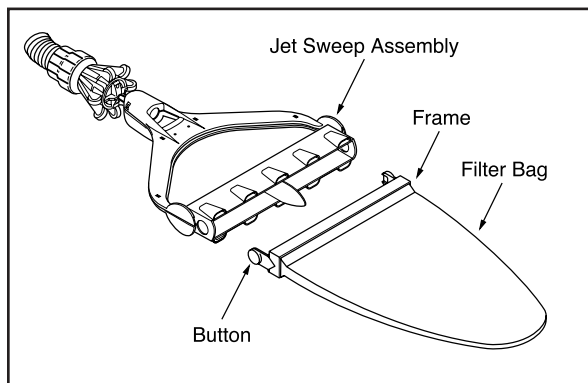

important to maintain a clean pool filter. A dirty filter can result in sluggish or inefficient operation. **Make sure the Polaris Turbo Turtle is disconnected from the pool wall before cleaning and backwashing the pool filter.**

A. Emptying the Filter Bag

1. Turn off the pool pump. Push in on the buttons and slide the filter bag off the jet sweep assembly.
2. Turn the filter bag inside out over a trash can. Reattach it making sure the frame of the filter bag is completely open.

B. Cleaning the Filter Screen

Inside the quick disconnect there is a filter screen. It acts as a safety filter to keep any debris that is not caught by your pool filtration system out of the Polaris. If the filter screen clogs often, consult your pool professional.

Please Note: Running the Polaris without the filter screen can damage the Polaris.

To clean the filter screen, pull it out of the quick disconnect. Rinse out the debris and press the filter screen firmly back into place.

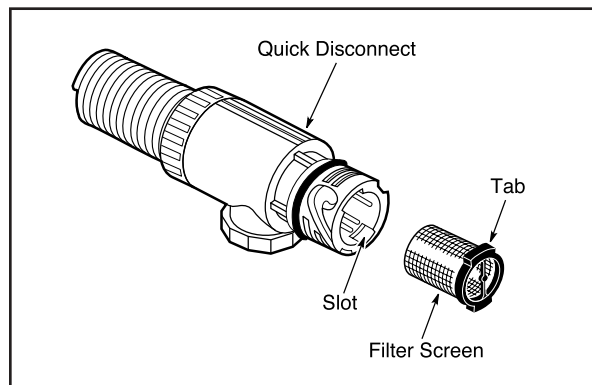

C. Backwashing the Pool Filter

Always disconnect the Polaris from the pool wall before cleaning or backwashing the pool filter. After cleaning or backwashing, let the pool filtration system run for at least five minutes to flush out the return lines before reconnecting the Polaris.

D. Storage and Winterizing

When storing the Polaris Turbo Turtle, remove the sweep hose and float hose from the surface module. Remove the jet sweep assembly from the sweep hose. Drain the surface module carefully. Turn it in all directions to aid in the removal of the water. **THIS IS ESPECIALLY IMPORTANT WHEN YOU ARE PUTTING THE POLARIS TURBO TURTLE AWAY FOR THE WINTER.** We suggest storing the surface module in a clean, dry and warm environment out of direct sunlight. The jet sweep assembly should lay flat and the hoses should lay or hang straight. You may want to purchase a hanger kit (part #6-109-00) for convenient hose storage. See Section E below and the diagram on page 4.

Remove the universal wall fitting when winterizing the pool. With the quick disconnect attached, pull the quick disconnect away from the wall as you unscrew the universal wall fitting. Leave the universal wall fitting attached to the quick disconnect while storing the Polaris. In some cases, it may be necessary to use a universal wall fitting removal tool (part #10-102-00) available from a participating Polaris dealer.

E. Accessories

1. Leaf Bag (Part #6-207-00)

The leaf bag is especially designed to collect larger, heavier types of debris such as large quantities of leaves and acorns.

2. Hanger Kit (Part #6-109-00)

The hanger kit is an ideal way to store the Polaris while it is not in use. It keeps the Polaris safe and out of the way. It also helps keep the hoses from coiling during prolonged storage.

3. WaterStars (Part #7-400-00) and WaterStars WF (Part #11-100-00)

Now you can instantly beautify your pool with a Polaris WaterStars or WF fountain. Choose a gentle rainfall display or a cascading waterfall display.

IV. Troubleshooting

The numbers in parentheses below refer to specific parts on the Exploded Parts Diagram on page 8. For best results, follow the troubleshooting solutions in the order they are listed. If none of these solutions work, contact our Customer Service Department at 1-800-VAC-SWEEP.

A. Problems and Solutions

Problem: Polaris Turbo Turtle does not clean the entire pool or runs slowly.

- Solution:
1. Feel around the pressure relief valve (#27). If it is not releasing excess water, clean or backwash the pool filter. See Section C on page 5.
 2. Check the filter screen (#33) in the quick disconnect for debris and clean it, if necessary. See page 5.
 3. Check that the float hose (#25) is adjusted correctly. See page 4.
 4. Check the surface module operation by following the steps below.
 - a. Remove the surface module top(#1) by unscrewing the two phillips-head screws (#14) from the body bottom (#11) and lifting slightly at the rear of the surface module top.
 - b. Turn on the Polaris. Make sure the randomizer tube (#8) is moving from front to back. If it is, refer to step c on page 7. If it is not, the filter connector (#8) may be clogged.

To check the filter connector, disconnect the float hose (#25) from the mechanism (#2) and look into the mechanism. About half way down in the center of the randomizer tube, you can see the white filter connector. If it is covered with debris or algae, remove the connector chamber (#9), pull on the randomizer tube and clean the filter connector. If it is not, the piston (#5) will need to be replaced.

- c. While the Polaris is operating, watch the randomizer ball (#7) in the mechanism (#2). If it does not move with two minutes and the randomizer tube (#8) is moving back and forth, the mechanism will need to be replaced.

5. Verify that the water pressure is between 5 and 10 psi. A pressure tester (part #6-113-00) is available through your participating Polaris dealer.

Problem: Surface module dives under the water or leans to one side.

- Solution:
1. Make sure the hoses are not twisted.
 2. Hold the surface module out of the water and drain. Shake the surface module. If there is water sloshing in the body bottom (#11), it will need to be drained.

To drain the body bottom, disconnect both the float hose (#25) and the sweep hose (#17) from the surface module. Remove the two phillips-head screws (#14) on the bottom of the surface module.

3. Unscrew the pressure relief valve (#27) until the holes are exposed. Adjust it in or out until the surface module levels off.
4. Verify that the water pressure is between 5 and 10 psi. A pressure tester (part #6-113-00) is available through your participating Polaris dealer.

Problem: The float hose remains coiled.

- Solution:
1. See "Polaris does not clean entire pool" on page 6.
 2. Lay the float hose (#25) out straight in the sun to remove the coils.

Problem: Surface module moves too fast.

- Solution:
1. Unscrew the pressure relief valve (#27) until the holes are exposed. Adjust it in or out until the surface module slows down.

2. Verify that the water pressure is between 5 and 10 psi. A pressure tester (part #6-113-00) is available through your participating Polaris dealer.

Problem: Bag does not stay on the pool floor.

- Solution:
1. Check that the bag (#23) has been installed correctly, see page 5.
 2. The flow of water through the Polaris Turbo Turtle could be too high. See "Surface module moves too fast."
 3. Check for air bubbles around the jet body assembly (#18). If bubbles are present, there may be air entering the plumbing line. Contact a pool professional.

B. Troubleshooting Worksheet

If none of the troubleshooting solutions worked, please fill in the following information and either contact your participating Polaris dealer or our Customer Service Department at 1-800-VAC-SWEEP (USA and Canada only) or (760) 599-9600.

In order to provide faster and more convenient service, have the following information available at the time of your call or when taking the Polaris in for service.

1. **Serial #:** _____
(See page 3 for the location of the serial #.)
2. **Is the hose the proper length?**
(See page 4.)
 Yes No
Length of the sweep hose: _____
Length of the float hose: _____
3. **Is the filter connector clear of debris?**
(See Solution 4b on page 6.)
 Yes No
4. **Are there any broken tabs on the mechanism?**
 Yes No

Polaris TurboTurtle

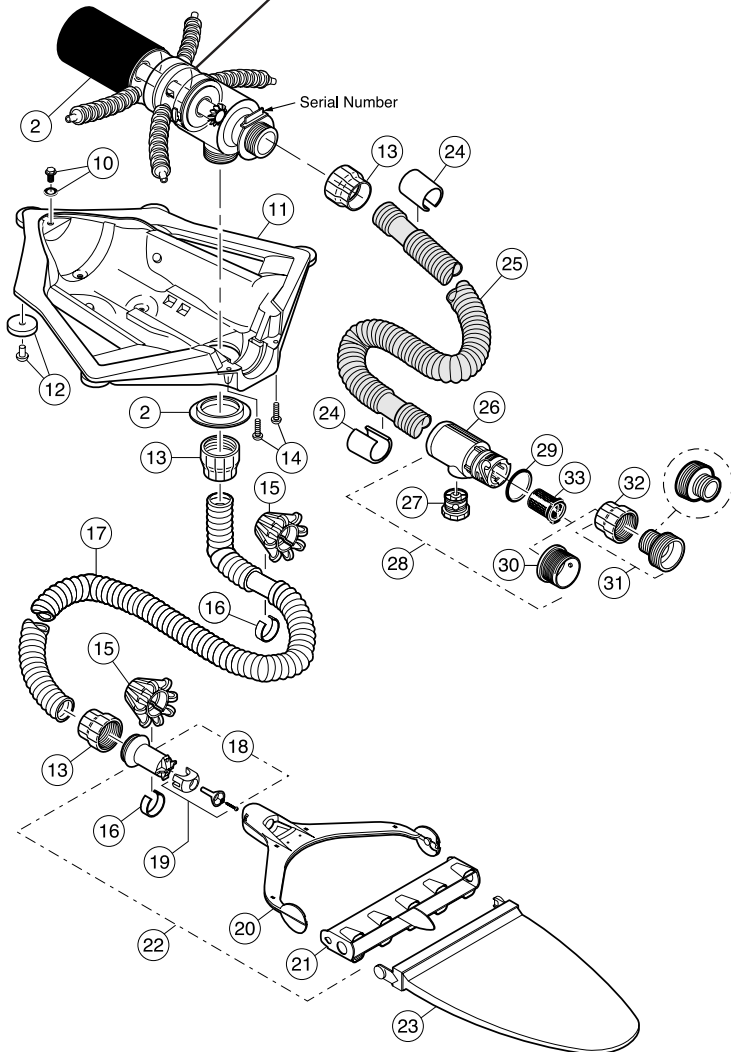
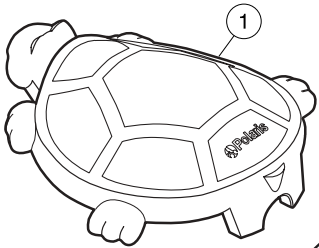
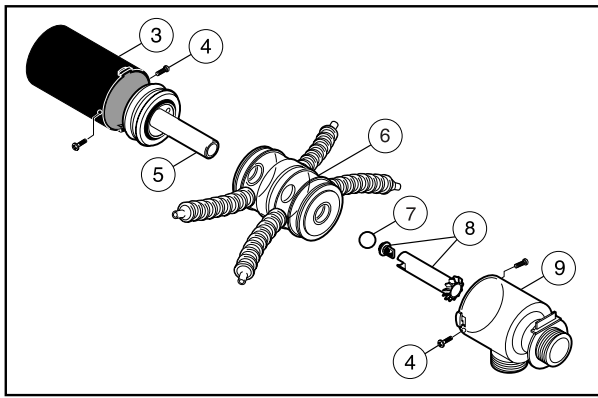

No.	Part #	Description	Qty
1	6-309-00	Turtle Top	1
2	6-400-00	Mechanism	1
3	6-407-00	Cylinder	1
4	6-413-00	Screw, Mechanism, #6 x 5/16" SS Sheet Metal, Blunt-end	4
5	6-411-00	Piston Assembly	1
6	6-412-00	Center Chamber Assembly	2
7	6-403-00	Randomizer Ball	1
8	6-406-00	Filter Connector/Randomizer Tube Kit	1
9	6-408-00	Connector Chamber	1
10	6-507-00	Drain Plug Assembly	1
11	6-305-00	Body Bottom Assembly, Gray	1
12	6-301-00	Body Bottom Wheel Kit, Gray	5
13	6-104-00	Hose Connector, Female	3
14	6-302-00	Screw, Top, #10 x 3/4" SS Sheet Metal, Pan Head	2
15	6-107-00	Wheel Cage Assembly	6
16	6-110-00	Hose Weight	6
17	6-106-00	Sweep Hose Complete, 7 Ft.	1
18	6-116-00	Jet Body Assembly	1
19	6-119-00	Jet Body Ball Kit	1
20	6-211-00	Jet Sweep Harness	1
21	6-210-00	Jet Sweep Head	1
22	6-212-00	Jet Sweep Assembly	1
23	6-206-00	All-Purpose Bag	1
24	6-222-00	Float, Gray	24
25	6-225-00	Float Hose, 24 Foot (Hose only), Gray	1
26	6-502-00	Quick Disconnect, UWF	1
27	6-503-00	Pressure Relief Valve	1
28	6-508-00	UWF Connector Assembly	1
29	6-505-00	O-ring, UWF/QD	1
30	6-500-00	Universal Wall Fitting (UWF)	1
31	6-510-00	UWF Adapter, 1-1/4" or 2"	1
32	6-512-00	UWF Adapter, 2"	1
33	6-504-00	Filter Screen, UWF/QD	1
Parts Not Shown			
	G-21	Ladder Guard, 2 Panels	
	6-101-00	Adapter Kit for 1-1/4" or 2"	
	6-103-00	Hose Connector, Male	
	6-109-00	Hanger Kit (Includes 8 brackets)	
	6-112-00	Sweep Hose, 10 Foot (Hose only)	
	6-113-00	In-line Pressure Tester	
	6-207-00	Leaf Bag	
	6-221-00	Float Hose Extension Kit, 8 Ft, Gray	
	6-511-00	UWF Eyeball Fitting	
	9-100-8006	Standard Eyeball Regulator Disk	
	10-102-00	UWF Removal Tool, Plastic	
	11-203-00	Adjustable Plug, UWF	

To ensure proper operation and long life for the Polaris, be sure to insist on genuine Polaris parts.

Limited Warranty **Polaris Vac-Sweep® Turbo Turtle™ Automatic Swimming Pool Cleaner**

This limited warranty is extended to the original consumer purchaser of this Polaris Vac-Sweep Turbo Turtle Automatic Swimming Pool Cleaner manufactured by Polaris Pool Systems, Inc., 2620 Commerce Way, Vista, California 92083-8438, U.S.A.

Polaris warrants the cleaning unit it manufactures, including all parts and components thereof, to be free of defects in material and workmanship. The Polaris Turbo Turtle is intended for use in aboveground swimming pools only. This warranty does not apply if the Polaris Turbo Turtle is used in any other type of pool. The warranty does not cover normal replacement items, including the filter bag. We do not cover improper installation of the Polaris Vac-Sweep Turbo Turtle. The instruction manual should be read in its entirety before the installation of the Polaris Vac-Sweep Turbo Turtle. All installation instructions should be carefully followed. Failure to follow the installation instructions may void this warranty. If you have any questions regarding your Polaris Vac-Sweep Turbo Turtle, please feel free to call or write us. Be sure to include the serial number, which can be located on the rear of your surface module above the float hose connection.

EXAMPLE: T 1 2 3 4 5 6

The Polaris Vac-Sweep Turbo Turtle body bottom is warranted for a period of three years. The rest of the Polaris Turbo Turtle parts are warranted for a period of one year from date of manufacture of the unit as established by the serial number, or one year from date of purchase with proof of purchase, whichever is later.

This limited warranty does not apply if the failure is caused or contributed to by any of the following: improper handling, improper usage, improper storage, winter freezing, abuse, improper installation, removal of the UWF filter screen, unsuitable application of the unit, improper maintenance, lack of reasonable and necessary maintenance, damage in transit or during installation, or damage from repairs/alterations made or attempted by anyone other than Polaris or one of its Authorized Service Centers. Polaris will repair or replace, at its option, a unit or part proved to be defective within the warranty period and under the conditions of the warranty.

In order to make a claim under this warranty, the consumer must deliver or ship the unit or warranty parts freight prepaid to the nearest Polaris Authorized Service Center or return it freight prepaid (after proper authorization) to the plant of manufacture. Authorization to return a unit or part to the plant of manufacture must be obtained from the Polaris Customer Service Department. Check with your dealer for the local procedure before exercising this warranty. If further directions or instructions should be required, contact the Customer Service Department at 1-800-VAC-SWEEP (USA and Canada only) or (760) 599-9600. Be sure you insure your shipments against loss or damage in transit.

Polaris is not responsible for the cost of removal of the unit or parts, damages during or due to removal, any other expenses incurred in shipping the unit or parts to or from the factory or its Authorized Service Centers, or damages during the installation of the repaired or replacement unit. The consumer must bear these expenses.

This warranty does not cover repair or replacement of a unit or part except at our plant of manufacture or a Polaris Authorized Service Center. This warranty does not cover pattern removal, abrasion or markings on a vinyl liner.

THIS LIMITED WARRANTY IS IN LIEU OF ALL OTHER WARRANTIES, EXPRESS OR IMPLIED, INCLUDING THE IMPLIED WARRANTIES OF MERCHANTABILITY AND FITNESS FOR A PARTICULAR PURPOSE, AND ALL SUCH OTHER WARRANTIES ARE DISCLAIMED EXCEPT TO THE EXTENT ANY IMPLIED WARRANTY MAY BE IMPOSED BY STATE CONSUMER LAW. ANY SUCH IMPLIED WARRANTY IMPOSED BY STATE CONSUMER LAW IS LIMITED IN DURATION TO ONE (1) YEAR FROM THE DATE OF PURCHASE.

IN NO EVENT SHALL POLARIS BE LIABLE FOR INCIDENTAL OR CONSEQUENTIAL DAMAGES OF ANY NATURE OR KIND OR FOR DAMAGES TO PERSONS OR PROPERTY, INCLUDING ANY DAMAGES RESULTING FROM THE USE OF THE POLARIS VAC-SWEEP TURBO TURTLE AUTOMATIC POOL CLEANER WITH A SUBSTANDARD POOL CIRCULATION SYSTEM.

Some states do not allow limitation on how long an implied warranty lasts, or the exclusion or limitation of incidental or consequential damages, so the above limitations may not apply to you.

This limited warranty is valid only in the United States of America, Canada and Australia, and it does not apply to Polaris Vac-Sweep Turbo Turtle Automatic Swimming Pool Cleaners sold or installed in any other country.



USA: 2620 Commerce Way, Vista, CA 92083-8438 • 760-599-9600 • 1-800-VAC-SWEEP (USA and Canada only)

Florida Warehouse: 10453 Tillery Road, Spring Hill, FL 34608

Australia: Unit 18, 1-7 Short Street, Chatswood, NSW 2067 • 02-9882-1111 • ACN 080 168 092

Europe: C/Osona s/n. (Pol. Ind. El Ramassar), 08520 Les Franqueses del Vallés, Barcelona, Spain • +34 93 840 25 85

www.polarispool.com

©2002 Polaris Pools Systems, Inc. All Rights Reserved. TL-1021 4/03