

# Installation and Operation Manual



## Jandy® Heat Pumps Model AE-Ti

### **DANGER**

**RISK OF ELECTRICAL SHOCK OR ELECTROCUTION.** The electrical supply to this product must be installed by a licensed or certified electrician in accordance with the National Electrical Code and applicable local codes and ordinances. Improper installation will create an electrical hazard, which could result in death or serious injury to pool or spa users, installers, or others due to electrical shock, and may also cause damage to property. Read and follow the specific instructions inside this manual.

### **DANGER**

**RISQUE DE CHOC ÉLECTRIQUE OU ELECTROCUTION.** Cet appareil doit être installé par un électricien certifié conformément au National Electrical Code et aux normes et réglementations locales. Une installation incorrecte peut entraîner un risque de problème électrique (choc électrique ou électrocution) pouvant causer des blessures graves et même la mort des installateurs et/ou utilisateurs de SPA et Piscines. Lire le manuel et se conformer aux directives.

### **PELIGRO**

**RIESGO DE DESCARGA ELÉCTRICA O ELECTROCUTAMIENTO.** El suministro eléctrico de este producto deberá ser instalado por un electricista autorizado o diplomado, de acuerdo al Código Eléctrico Nacional y a los códigos y normativas que apliquen localmente. Una instalación inadecuada podría originar riesgos eléctricos y ocasionar la muerte o lesiones graves a los usuarios de la piscina o spa, instaladores u otros, como consecuencia de una descarga eléctrica, pudiendo así mismo ocasionar daños a la propiedad. Léa y siga las instrucciones específicas que se recogen en este manual.



## Table of Contents

<b>Section 1. General Information .....3</b>	
1.1 Introduction..... 3	
1.2 Consumer Information and Safety..... 3	
1.2.1 Spa/Hot Tub Safety Rules..... 3	
1.2.2 Swimming Pool Energy Saving Tips ..... 4	
1.3 Warranty ..... 4	
1.4 Codes and Standards ..... 4	
1.5 Technical Assistance..... 5	
1.6 Materials Needed For Installation..... 5	
1.6.1 Materials for All Installations ..... 5	
1.6.2 Recommended Materials for Installations..... 5	
1.7 Specifications..... 5	
1.7.1 General Specifications ..... 5	
1.7.2 Dimensions ..... 5	
1.7.3 Technical Specifications..... 5	
 <b>Section 2. Installation Instructions .....5</b>	
2.1 General Information..... 5	
2.2 Location Requirements..... 5	
2.2.1 Introduction ..... 5	
1.7.3 Technical Specifications..... 6	
2.2.2 Clearances..... 7	
2.2.3 Equipment Pad ..... 7	
2.2.4 Condensation and Drainage ..... 7	
2.2.5 Lawn Sprinklers ..... 8	
2.2.6 Roof Run-off..... 8	
2.2.7 Installation of Anchor Clamps ..... 8	
 <b>Section 3. Water Connections .....8</b>	
3.1 Plumbing Layout ..... 8	
3.2 Water Connections at Heat Pump ..... 9	
3.3 Check Valve Installation..... 9	
3.4 Automatic Flow Control Valve..... 9	
3.5 Multiple Unit Installation..... 9	
3.5.1 Heat Pump and Heater Combination..... 9	
3.5.2 Multiple Heat Pump Connections..... 10	
 <b>Section 4. Electrical Connections .....10</b>	
4.1 General Information ..... 10	
4.2 Main Power..... 10	
4.3 Bonding..... 10	
4.4 Pump Connection (Maintain Temp Feature)..... 16	
4.5 Optional Remote Controls ..... 16	
4.5.1 Connection to a Remote Pool-Off-Spa Selector (3-Wire Connection)..... 16	
4.5.1.1 Install the Remote Pool-Off-Spa Selector..... 16	
4.5.1.2 Configure the Control Panel ..... 16	
4.5.2 Two-Wire Connection to an AquaLink® RS or TSTAT ..... 17	
4.5.2.1 Configure the AquaLink® RS Control System..... 17	
4.5.2.2 Install the Remote TSTAT ..... 17	
4.5.2.3 Configure the Control Panel ..... 17	
4.5.3 Four-Wire Connection to AquaLink® RS 485 Communication ..... 18	
4.5.4 Connection to a Secondary User Interface ..... 18	
 <b>Section 5. Operation.....19</b>	
5.1 Initial Start-up Precautions..... 19	
5.2 Operating the Controller ..... 19	
5.2.1 Off Mode ..... 19	
5.2.2 Pool Mode - (Normal Heat)..... 19	
5.2.3 Pool Mode - (Optional Maintain Heat)..... 20	
5.2.4 Spa Mode - (Normal Heat)..... 20	
5.2.5 Spa Mode - (Optional Maintain Heat) ..... 20	
5.3 Operating Features of Hybrid Units with Optional Chiller ..... 20	
5.3.1 Pool Mode - (Normal Chill)..... 20	
5.3.2 Pool Mode - (Optional Maintain Chill) ..... 20	
5.3.3 Spa Mode - (Optional Maintain Chill)..... 20	
5.4 User Setup Options ..... 21	
5.4.1 Language Setup..... 21	
5.4.2 Temperature Scale Setup ..... 21	
5.4.3 Spa Timer Setup ..... 21	
5.4.4 Display Light Setup ..... 21	
5.5 Set Point Lockout..... 21	
5.6 Water Pressure Switch Adjustment..... 22	
 <b>Section 6. General Maintenance .....23</b>	
6.1 Water Chemistry ..... 23	
6.2 Winterizing ..... 23	
6.3 Spring Start-Up..... 24	
6.4 Inspection and Service ..... 24	
6.4.1 Owner Inspection ..... 24	
6.4.2 Professional Inspection..... 25	
 <b>Section 7. Professional Maintenance and Service .....25</b>	
7.1 Heat Pump Design..... 25	
7.2 Heat Pump Components and Operation..... 25	
 <b>Section 8. Troubleshooting .....26</b>	
8.1 Troubleshooting Guide..... 26	
8.2 Diagnostics ..... 27	
 <b>Section 9. Replacement Parts .....28</b>	
9.1 Ordering Information..... 28	
9.2 Jandy AE-Ti Heat Pumps Parts List..... 28	
9.3 Jandy AE-Ti Heat Pumps Exploded View ..... 29	

## Figures and Tables

<p>Figure 1. Jandy AE-Ti Heat Pumps Dimensions ..... 6</p> <p>Figure 2. Anchor Clamp Positions..... 9</p> <p>Figure 3. Anchor Clamp Installation ..... 9</p> <p>Figure 4. Standard Plumbing Layout..... 11</p> <p>Figure 5. Plumbing For Heating System Combinations ..... 11</p> <p>Figure 6. Two Heat Pump Plumbing Layout..... 12</p> <p>Figure 7. Four Heat Pump Plumbing Layout..... 12</p> <p>Figure 8. AE-Ti Single-Phase Electrical Supply Wiring Diagram ..... 13</p> <p>Figure 9. AE-Ti 3-Phase Electrical Supply Wiring Diagram ..... 14</p> <p>Figure 10. Example of Maintain Temp Wiring to the Time Clock ..... 15</p> <p>Figure 11. AE-Ti Heat Pump Front View ..... 15</p> <p>Figure 12a. Remote Pool-Off-Spa Connection (3-Wire Connection)..... 16</p> <p>Figure 12b. AquaLink RS or Remote TSTAT Connection (2-Wire Connection)..... 16</p> <p>Figure 13. AquaLink RS to AE-Ti Heat Pump ..... 17</p> <p>Figure 14. AE-Ti Heat Pump Connection to Power ..... Center ..... 18</p> <p>Figure 15. Main Control Panel ..... 19</p> <p>Figure 16. Winterizing the AE-Ti Heat Pump..... 23</p> <p>Figure 17. Heat Pump Operation Overview ..... 25</p> <p>Figure 18. Jandy AE-Ti Heat Pumps Exploded View ..... 29</p>	<p>Table 1. AE-Ti Heat Pump Technical Specifications ..... 6</p> <p>Table 2. Heat Pump Clearances ..... 7</p> <p>Table 3. Optimal Water Chemistry Ranges..... 23</p> <p>Table 4. Heat Pump Troubleshooting Guide ..... 26</p> <p>Table 5. Heat Pump Diagnostics ..... 27</p>
--	--

## Section 1. General Information

### 1.1 Introduction

This manual provides installation and operation instructions for the Jandy AE-Ti models of heat pumps. Read these installation and operation instructions completely before proceeding with the installation. Consult Jandy with any questions regarding this equipment. To obtain additional copies of this manual contact us at 707-776-8200 ext. 237. The following is the address information for Jandy:

2735 NW 63rd Court.  
Fort Lauderdale, FL USA 33309

The AE-Ti heat pump gets electrical power from an external source and provides a dual digital thermostat control system for pool/spa combinations or preheat convenience.

This heat pump is specifically designed for heating fresh water swimming pools and spas. Do not use it as a general service heater. Consult your dealer for the appropriate Jandy products for these applications.

**NOTE** "Fresh water swimming pools and spas" include systems that utilize saltwater chlorine generator units, such as the Jandy AquaPure Electronic Chlorine Generator. Please ensure that the salt content of the pool/spa *does not exceed* 4000 ppm and water flow rate is within 30-125 gpm (110-125 lpm)

#### ATTENTION

**Installation and service must be performed by a qualified installer or service agency.**

#### To the Installer:



After installation, these instructions must be given to the homeowner or left on or near the heat pump.

#### To the User:

This manual contains important information that will help you in operating and maintaining this heat pump. Please retain it for future reference.

### 1.2 Consumer Information and Safety

The AE-Ti series of heat pumps are designed and manufactured to provide many years of safe and reliable service when installed, operated and maintained according to the information in this manual and the installation codes referred to in later sections. Throughout the manual, safety warnings and cautions are identified by the "⚠" symbol. Be sure to read and comply with all of the warnings and cautions.

### 1.2.1 Spa/Hot Tub Safety Rules

#### ⚠ WARNING

The U.S. Consumer Product Safety Commission warns that elevated water temperature can be hazardous. Consult heater operation and installation instructions for water temperature guidelines before setting temperature.

#### ⚠ AVERTISSEMENT

La Commission U.S. de Sécurité des Produits pour les Consommateurs indique que des températures de l'eau élevées peuvent être dangereuses. Voir la notice d'installation et de fonctionnement pour le réglage de la température.

#### ⚠ AVISO

La Comisión de Seguridad de Productos para el Consumidor de los Estados Unidos, advierte que una temperatura elevada del agua puede ser peligrosa. Consulte las instrucciones de instalación y funcionamiento del calentador para seguir las directrices relacionadas con la temperatura del agua antes de proceder a fijar la temperatura.

#### ⚠ WARNING

The following "Safety Rules for Hot Tubs," recommended by the U.S. Consumer Product Safety Commission, should be observed when using the spa.

#### ⚠ AVERTISSEMENT

Les Règlements suivants pour Cuves Thermales, tel que recommandés par la Commission U.S. de Sécurité des Produits pour les Consommateurs, devraient être respectés lors de l'utilisation du spa.

#### ⚠ AVISO

Al utilizar el spa, deberán observarse, las siguientes "Reglas de Seguridad para Baños Calientes" recomendadas por la Comisión de Seguridad de Productos para el Consumidor de los Estados Unidos.

1. Spa or hot tub water temperature should never exceed 104°F (40°C). One hundred degrees Fahrenheit (100°F [38°C]) is considered safe for a healthy adult. Special caution is recommended for young children.
2. The drinking of alcoholic beverages before or during spa or hot tub use can cause drowsiness which could lead to unconsciousness, and subsequently result in drowning.

3. **Pregnant women take note!** Soaking in water above 102°F (38.5°C) can cause fetal damage during the first three months of pregnancy (which could result in the birth of a brain-damaged or deformed child). If pregnant women are going to use a spa or hot tub, they should make sure the water temperature is below 100°F (38°C) maximum.
4. The water temperature should always be checked with an accurate thermometer before entering a spa or hot tub. Temperature controls may vary by as much as 1F° (1C°).
5. Persons with a medical history of heart disease, diabetes, circulatory or blood pressure problems should consult their physician before using a hot tub or spa.
6. Persons taking any medication which induces drowsiness (e.g., tranquilizers, antihistamines, or anticoagulants) should not use spas or hot tubs.
7. Prolonged immersion in hot water can induce hyperthermia.

Hyperthermia occurs when the internal body temperature reaches a level several degrees above the normal body temperature of 98.6°F (37°C). Symptoms include dizziness, fainting, drowsiness, lethargy, and an increase in the internal body temperature. The effects of hyperthermia include:

- Lack of awareness of impending hazard
- Failure to perceive heat
- Failure to recognize need to leave spa
- Physical inability to leave spa
- Fetal damage in pregnant women
- Unconsciousness resulting in a danger of drowning

### 1.2.2 Swimming Pool Energy Saving Tips

It is important to note that a heat pump will not heat a pool as fast as a large gas or electric pool heater. If the pool water is allowed to cool significantly, it may take several days to return to the desired swimming temperature. For weekend use, it is *more economical* to maintain the pool water temperature at or near your desired swimming temperature. If you do *not* plan to use your pool for a prolonged period, then you might choose to turn the heat pump completely off *or* decrease the temperature setting of the control several degrees to minimize energy consumption.

Jandy offers the following recommendations to help conserve energy and minimize the cost of operating your heat pump without sacrificing comfort.

1. The American Red Cross recommends a maximum water temperature of 78°F (25°C). Use an accurate pool thermometer. A difference of 4°F (2°C), between 78°F and 82°F (26°C and 28°C), will significantly increase energy consumption.
2. Carefully monitor the water temperature of your pool in the summertime. You can reduce heat pump usage due to warmer air temperatures.
3. During the winter or when on vacation for longer than a week, turn off the heat pump.
4. Find the proper setting on the heat pump temperature control and use the Set Point Lockout or lock the cover on the heat pump controller to discourage further adjustments.
5. Set the pump time clock to start the pump no earlier than 6:00 AM during the pool heating season. This is the time when nightly heat loss balances.
6. Where possible, shelter the pool from prevailing winds with well-trimmed hedges or other landscaping, cabanas, or fencing.
7. Always use a pool cover when practical. Besides providing a valuable safety feature, a pool cover will reduce heat loss, conserve chemicals, and reduce the load on filter systems.

## 1.3 Warranty

The AE-Ti heat pump is sold with a limited factory warranty. Details are specified on the back cover of this manual.

Make all warranty claims to an authorized Jandy dealer or directly to the factory. Claims must include the heat pump serial number and model (this information can be found on the rating plate), installation date, and name of the installer. Shipping costs are not included in the warranty coverage.

The warranty does not cover damage caused by improper assembly, installation, operation, winterizing, field modification, or failure to earth bond and properly ground the unit. Any changes to the heat pump, evaporator, heat exchanger, wiring, or improper installation may void the warranty.

## 1.4 Codes and Standards

The AE-Ti heat pump is listed by ETL as complying with the latest edition of the “UL Standard for Safety for Heating and Cooling Equipment”, UL 1995 and CSA C22.2 No. 236.

All Jandy heat pumps must be installed in accordance with the local building and installation codes as per the utility or authority having jurisdiction. All local codes take precedence over national codes. In the absence of local codes, refer to the latest edition of the National Electrical Code (NEC) in the United States and the Canadian Electrical Code (CEC) in Canada for installation.

## 1.5 Technical Assistance

Consult Jandy Technical Support Department or your local Jandy dealer with any questions or problems involving the specifications, installation, and operation of your Jandy equipment. An experienced technical support staff is ready to assist you in assuring the proper performance and application of Jandy products. For technical support call the Jandy Heat Pumps Technical Service Department at (954) 970-4800.

## 1.6 Materials Needed For Installation

### 1.6.1 Materials for All Installations

The following items are needed and are to be supplied by the installer for *all* heat pump installations:

1. Plumbing connections (2").
2. Level surface for proper drainage.
3. Suitable electrical supply line. See rating plate on unit for electrical specifications. A junction box is not needed at the heat pump; connections are made inside of the heat pump electrical compartment. Conduit may be attached directly to the heat pump jacket.

- NOTE** Flex conduit is recommended for connecting the electrical supply wires to the heat pump so that the front panel may be removed easily for servicing.
4. Electric cutout switch that will interrupt all power to the unit. This switch *must* be within line of sight of the heat pump.
  5. Watertight conduit to run the electrical supply line.

### 1.6.2 Recommended Materials for Installations

Jandy recommends installing isolation valves on the inlet and outlet water connections for ease of serviceability.

## 1.7 Specifications

### 1.7.1 General Specifications

Suitable for indoor and outdoor use. Clearances shown in Table 2 must be adhered to.

#### Water Pipe/Heater Connection

Plastic 2" PVC (Unions included)

#### Flow Rate

Maximum	125 gpm (475 lpm)
Optimum	55 gpm (210 lpm)
Minimum	30 gpm (110 lpm)

#### Maximum Working Water Pressure

75 psi

## Electrical Supply

### Voltage Requirements

1-Phase	208/230 VAC 60Hz
3-Phase	208/230 VAC 60Hz (Model dependent)

### 1.7.2 Dimensions

See Figure 1 for a diagram showing the heat pump's dimensions and for dimensions to critical connections.

### 1.7.3 Technical Specifications

See Table 1 for the AE-Ti Heat Pump Technical specifications.

## Section 2. Installation Instructions

### 2.1 General Information

Install the Jandy heat pumps in accordance with the procedures in this manual, local codes and ordinances, and in accordance with the latest edition of the appropriate national code. (See Section 1.4, "Codes and Standards".) Correct installation is required to assure safe operation. The requirements for Jandy heat pumps include the following:

1. Field assembly (if required).
2. Appropriate site location and clearances.
3. Sufficient air ventilation.
4. Proper electrical wiring.
5. Adequate water flow.

This manual provides the information needed to meet these requirements. Review all application and installation procedures completely before continuing the installation.

### 2.2 Location Requirements

#### 2.2.1 Introduction

**NOTE** Indoor installations require special considerations for condensate drainage and venting the cold air produced by the heat pump. Contact the Jandy Heat Pump Technical Service Department at (954) 970-4800.

#### CAUTION

When pool equipment is located below the pool surface, a leak from any component can cause large scale water loss or flooding. Jandy Pool Products, Inc. cannot be responsible for such water loss or flooding or resulting damage.

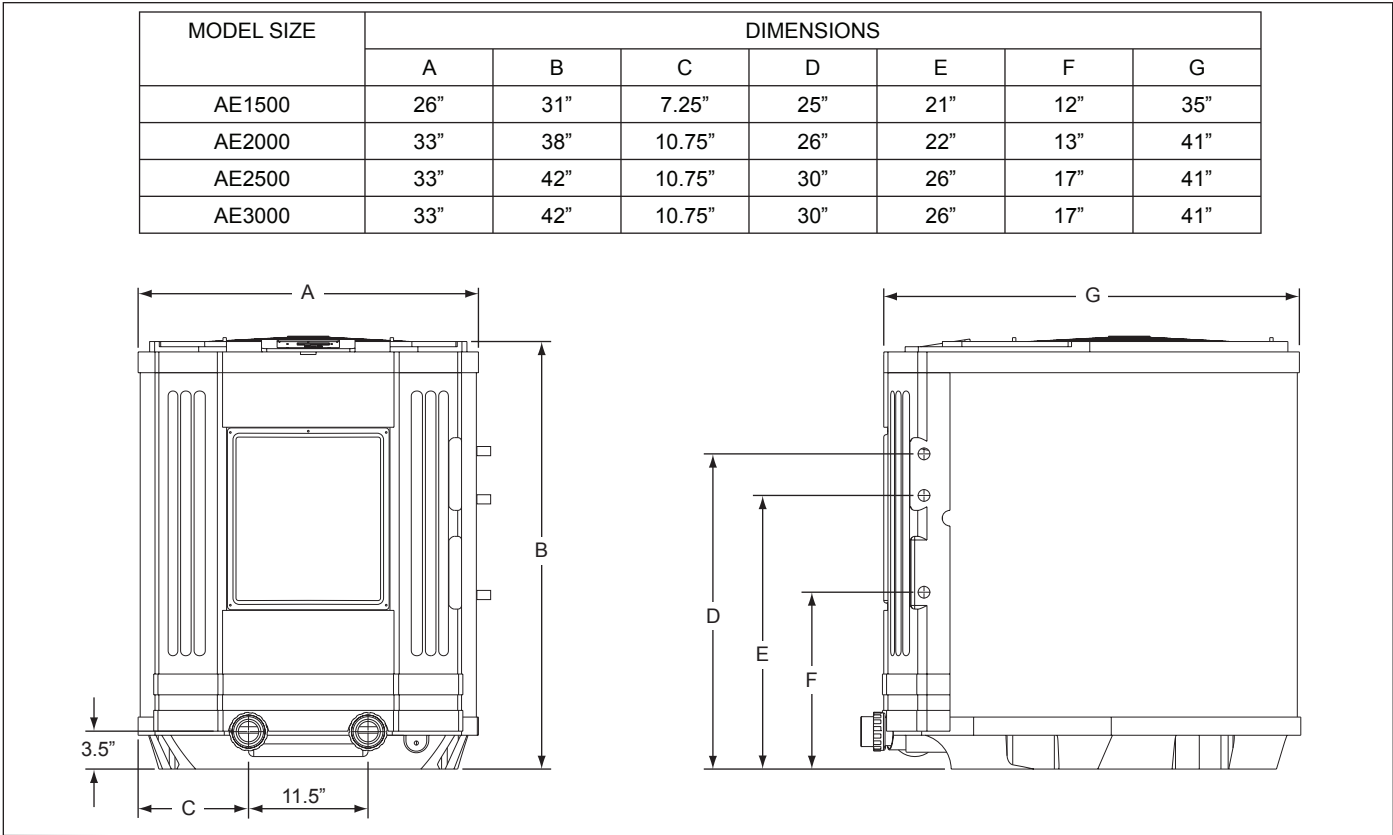

**Figure 1. Jandy AE-Ti Heat Pumps Dimensions**

MODEL	AE1500T	AE2000T	AE2000T-263	AE2500T	AE2500T-263	AE3000T	AE3000T-263
VOLTAGE/FREQUENCY/PHASE	208-230/60/1	208-230/60/1	208-230/60/3	208-230/60/1	208-230/60/3	208-230/60/1	208-230/60/3
OUTPUT	73,000 BTUs	103,000 BTUs		118,000 BTUs		135,000 BTUs	
COP	5.6	5.4		5.5		5.9	
MINIMUM CIRCUIT AMPACITY	28A	40A	24A	40A	29A	48A	31A
MAX OVER CURRENT PROTECTION	48A	68A	39A	68A	48A	80A	50A
HEAT EXCHANGER	Titanium						
COMPRESSOR	40K Scroll	60K Scroll		68K Scroll		81K Scroll	
CABINET	ABS						
REFRIGERANT	56 Oz, R-22	72 Oz, R-22		108 Oz, R-22		116 Oz, R-22	
REFRIGERANT HIGH PRESSURE ALARM	450 PSI (reset at 285 PSI)						
REFRIGERANT LOW PRESSURE ALARM	30 PSI (reset at 74 PSI)						
LOW WATER FLOW ALARM	30 GPM						
MAXIMUM HEIGHT BELOW WATER LEVEL	11 feet below pool level						
MAXIMUM HEIGHT ABOVE WATER LEVEL	5 feet above pool level						
OPTIMAL WATER FLOW	55 GPM						
MINIMUM WATER FLOW	30 GPM						
MAXIMUM WATER FLOW	125 GPM						
AIR FLOW	2060 CFM	4120 CFM					
WATER TEMPERATURE DIFFERENTIAL (DELTA T)	Adjustable between 1°F to 5°F						
UNION SIZE	2"						
WEIGHT	225 LBS	325 LBS					
SOUND PRESSURE PER ISO 3471	58.9 dBa						

**Table 1. AE-Ti Heat Pump Technical Specifications**



**⚠ ATTENTION**

Lorsque l'équipement d'une piscine est situé sous la surface de l'eau, une fuite provenant de n'importe quel élément peut causer une perte d'eau importante ou une inondation. Jandy Pool Products, Inc. n'est pas responsable des pertes d'eau, des inondations ou des avaries causées par une installation ou un entretien inadéquat.

**⚠ PRECAUCIÓN**

Cuando el equipo de la piscina esté situado por debajo de la superficie de la piscina, la fuga de cualquiera de los componentes, podría ocasionar la pérdida de grandes cantidades de agua o inundación. Jandy Pool Products, Inc. no se responsabilizará de dichas pérdidas de agua o inundaciones, ni de los daños que puedan derivarse de las mismas.

Aux Etats-Unis, ce chauffe-piscine doit être installé à au moins 5 pieds (1,5 m) de la paroi interne de la piscine à moins d'être isolé de la piscine par une clôture, un mur ou autre barrière permanente.

En Estados Unidos, esta bomba de calor deberá instalarse a una distancia de al menos 5 pies (1,5 metros) de la pared interior de la piscina; a menos que la bomba de calentar esté separada de la piscina mediante una valla sólida de 5 pies (1,5 metros) de altura u otra barrera permanente.

In Canadian installations, the minimum distance to be maintained from the inside wall of the pool or spa is 3 meters (approx. 10 feet).

Pour les installations canadiennes, la distance minimale à maintenir du mur intérieur de la piscine ou du spa est de 3 mètres (approximativement 10 pieds).

Avoid placing the heat pump in locations where it can cause damage by water or condensate leakage. If this is not possible, provide a suitable drain pan to catch and divert any leakage.

All criteria given in the following sections reflect minimum clearances. However, each installation must also be evaluated, taking into account the prevailing local conditions such as proximity and height of walls, and proximity to public access areas.

**2.2.2 Clearances**

The heat pump must be placed to provide clearances on all sides for maintenance and inspection. See Table 2.

24" (60 cm) access in front of the heat pump provides adequate room for serviceability.

If the heat pump is to be installed in a garage or under a vertical overhang, the unit must have a minimum of 5 feet clearance from the top of the heat pump.

In the U.S., the heat pump must be installed at least 5 feet (1,5 meters) from the inside wall of the pool or spa unless the heat pump is separated from the pool or spa by a 5 foot high solid fence or other permanent barrier.

**2.2.3 Equipment Pad**

Place the heat pump on a flat slightly pitched surface, such as a concrete or fabricated slab (pad). This allows proper drainage of condensation and rain water from the base of the unit. If possible, the pad should be placed at the same level or slightly higher than the filter system equipment pad.

**NOTE** Ensure that the pad is pitched not more than ¼ inch per foot toward the compressor end (front) of the heat pump. Pitch slab from back to front ¼ inch per foot maximum and level from side to side.

**2.2.4 Condensation and Drainage**

Condensation will occur from the evaporator coil while the unit is running and drain at a steady rate, usually three to five gallons per hour, depending upon ambient air temperature and humidity. The more humid the ambient conditions, the more condensation will be produced. The bottom of the unit acts as a tray to catch

**Table 2. Heat Pump Clearances**

Side of Heat pump	Minimum Clearances for Operation		Recommended Clearances for Serviceability	
	Inches	Centimeters	Inches	Centimeters
Front	6	15	24	60
Rear	6	15	12	30
Left	6	15	12	30
Right	6	15	12	30
Top	60	150	60	150

**NOTE** Clearances listed in Table 2 are manufacturer's tested values. These are given as minimum values. Where local and national codes apply, and values are different than those listed in Table 2, use the greater value to ensure safe and proper operation.

rainwater and condensation. Keep the drain hole located on the right side of the base of the unit clear of debris.

If the heat pump is installed indoors, means of condensate disposal must be provided. The drain hole in the base of the heat pump is tapped to fit an optional 3/4" diameter barbed adapter, Jandy p/n R3004100 (see Section 9, "Replacement Parts"). If using the barbed adapter, connect a length of 3/4" tubing (5' is included in Jandy p/n R3004100) to the adapter, then route it into a drain or outside the building to dispose of the condensate. ***It is important to remember that no part of the tubing or hose may be above the level of the drain hole in the base of the heat pump.***

### 2.2.5 Lawn Sprinklers

Keep lawn sprinkler heads from spraying on the heat pump to prevent corrosion and damage. Use a deflector if needed.

### 2.2.6 Roof Run-off

Make sure the heat pump is not located where large amounts of water may run-off from a roof into the unit. Sharp sloping roofs without gutters will allow massive amounts of rain water, mixed with debris from the roof to be forced through the unit. A gutter or down spout may be needed to protect the heat pump.

### 2.2.7 Installation of Anchor Clamps

In Florida, building codes require that the heat pump be anchored to the equipment pad or platform to withstand high wind pressures created during hurricanes. This heat pump is provided with anchor clamps designed to hold the unit to the equipment pad in high wind conditions. Installation of the anchor clamps is recommended in all installations and are required in Florida (reference Florida Building Code, Mechanical Section 301.13).

To install the anchor clamps:

1. Be sure that the heat pump is in its permanent location on the equipment pad.
2. Remove the anchor clamps from the installation and instruction package.

**NOTE:** Bolts and bolt anchors are not included with the heat pump. Jandy recommends that a 1/4" x 1 1/2" long stainless steel Tapcon® type concrete screw is used to mount the clamp to the equipment pad. The Tapcon type concrete screw meets Florida building code requirements.

3. Place the clamps at the base of the heat pump in the locations indicated in Figure 2.

**NOTE:** To Install the brackets on the *front* of the heat pump, the front cover must be loosened enough in order to place the bracket over the lip of the base. Be sure to re-tighten the front jacket panel to the heat pump.

4. Fit the hook of each clamp over the lip on the base panel of the heat pump. The hook should fit between the lip of the base panel and the evaporator coil guard (see Figure 3).
5. Mark the position of the hole in each clamp on the equipment pad.
6. Drill a hole in the cement using a masonry drill bit, with a diameter as determined by the concrete anchor, at each of the marks on the equipment pad. The hole should be approximately 1-1/2" deep.
7. Insert a bolt anchor into each of the holes. Be sure the anchors are set completely into the holes.
8. Position the anchor clamps so that the holes in the clamps are over the bolt anchors. Be sure that the clamp hooks are over the lip of the heat pump base (see Figure 3).
9. Insert an anchor bolt through each clamp into the anchor and tighten to secure the clamp and heat pump to the equipment pad.

## Section 3. Water Connections

### 3.1 Plumbing Layout

Figure 4 illustrates the standard plumbing layout with a single heat pump unit. Following the diagram from right to left, the plumbing sequence is as follows:

**Pool > Pool Pump > Filter > Heat Pump > Check Valve > Chemical Loop > Chlorinator > Pool**

**NOTE** For normal installations, do not install a shutoff valve or any kind of variable restriction in the water piping between the heat pump outlet and the pool/spa.

Arrangement of pool system components other than as illustrated in the preceding and following diagrams can affect the operation of the heat pump's water pressure switch. Location of the heat pump above or below the pool water surface can also affect operation of the switch. In general, the pressure switch can be adjusted to accommodate this effect if the heat pump water connections are no more than five feet below the pool water surface or no more than 11 feet above it. See instructions for pressure switch adjustment (Section 5.6) in the heat pump start-up section of this manual for more information. If the heat pump is installed outside of this range, an external flow switch may need to be installed in the plumbing upstream of the heat pump. Call the Jandy Heat Pump Technical Service department at (954) 970-4800 for details.

Be advised that when pool equipment is located below the pool surface a leak can result in large scale water loss or flooding. Jandy cannot be responsible for such water loss or flooding or the damage caused by either occurrence.

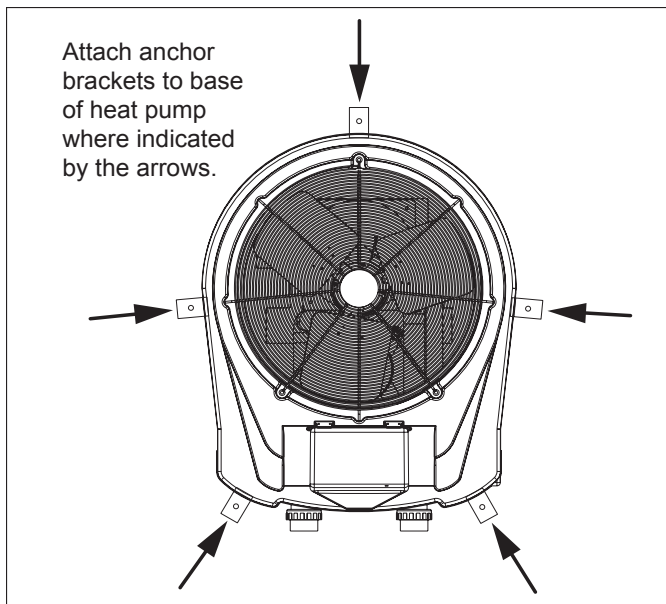

Figure 2. Anchor Clamp Positions

### 3.2 Water Connections at Heat Pump

Shipping plugs have been installed in the water inlet and outlet ports of the heat pump at the factory. Before installing any plumbing, remove the shipping plugs. Filtered water is plumbed to the inlet, located on the right side of the heat pump front panel. Heated water flows through the outlet, located on the left side of the heat pump front. Two inch unions are provided.

Plastic piping (PVC Schedule 40) should be connected to the heat pump. The unions, provided with the unit, accept 2" PVC pipe.

**CAUTION**

Make sure that flow requirements and pool water turn over rates can be maintained with the installation of additional heat pumps and plumbing restrictions.

**ATTENTION**

Assurez-vous que la circulation d'eau requise soit maintenue même si des pompes d'appoints ou des éléments de plomberie, causant des restrictions, sont ajoutés.

**PRECAUCIÓN**

Asegúrese de que los requerimientos de flujo e índices de volumen de agua de la piscina puedan mantenerse, con la instalación de bombas de calentar adicionales y restricciones de fontanería.

### 3.3 Check Valve Installation

The heat pump must be protected from back-siphoning of water. If there is any chance of back-siphoning, provide a check valve between the pool and the filter pump inlet.

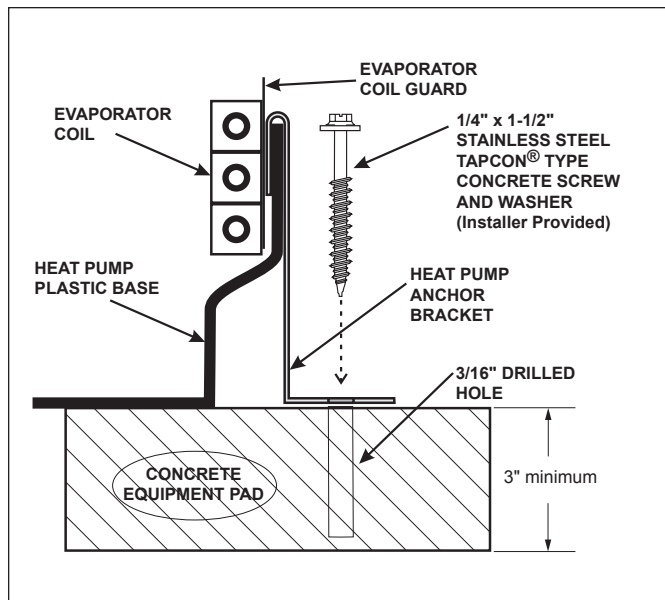

Figure 3. Anchor Clamp Installation

When an automatic chemical feeder is installed in the plumbing, it must be installed downstream of the heat pump. A check valve must be installed between the heat pump and the chemical feeder to prevent back-siphoning of chemically saturated water into the heat pump where it will damage the components.

### 3.4 Automatic Flow Control Valve

The inlet/outlet header of the AE-Ti heat pump comes equipped with an internal automatic flow control valve. The automatic flow control valve maintains the proper flow through the heat pump at rates up to approximately 125 gpm (475 lpm). If the filter system flow rate is higher than approximately 125 gpm (475 lpm), install a manual bypass valve (see Figure 4).

**NOTE** Be advised that if your circulation pump is over 2 HP or if the total flow exceeds 125 gpm, you will have to add an external bypass valve.

### 3.5 Multiple Unit Installation

#### 3.5.1 Heat Pump and Heater Combination

In certain regions of the country it may be more economical to run a heat pump during the warmer months and a gas heater during the cooler months.

In some situations it may be desirable to run the heat pump in the "Chiller" mode during the hottest portion of the year and a heater during the cooler months.

The Jandy heat pump may be plumbed with a gas or electric heater or any combination of heat sources including solar. All heat sources must be plumbed in parallel to work correctly and efficiently.

Figure 5 illustrates a recommended plumbing layout for a heat pump / heater / solar combination heating system for a pool / spa combination. Your

system may not contain all of these components, but the basic plumbing will apply by eliminating the component in the illustration that is not a part of your system.

### 3.5.2 Multiple Heat Pump Connections

All plumbing on multiple heat pump installations must be done in parallel (see Figures 6 and 7). An equal flow of water to each heat pump is important for optimum operation.

**NOTE** It may be necessary to adjust water pressure switch if a unit is installed below the water level. See Section 5.6 for details on when and how to adjust the pressure switch.

**NOTE** Each heat pump allows a maximum flow rate of 125 gpm and requires a minimum of 30 gpm.

## Section 4. Electrical Connections

### 4.1 General Information

Wiring connections must be made exactly as shown in the wiring diagram found on the inside of the heat pump access compartment (see Figure 8 for single phase electrical wiring and Figure 9 for 3-phase electrical wiring). The heat pump must include a definite means of grounding and bonding. There is a bonding lug on the right side of the heat pump, where a bond wire must be attached.

### 4.2 Main Power

Electrical wiring to the heat pump must be in accordance with the latest edition of the National Electric Code (NEC), ANSI/National Fire Protection Association (NFPA) 70 in the United States, and in Canada, the Canadian Electrical Code (CEC) C22.1, unless local code requirements indicate otherwise.

The heat pumps come factory-wired intended for use with either 208/230 VAC, 60 Hz single phase or 3 phase field electrical supply depending on the model. See the rating plate for the electrical specifications. All wiring must be done by a certified electrician.

The following is the procedure to wire the AE-Ti to the electrical source specified on the Rating Plate:

1. Be sure the power to the circuit for the heat pump is turned off.
2. Remove the four (4) screws that attach the service/access panel to the heat pump unit (see Figure 11).
3. Remove the front cover of the sheet metal junction box.
4. Electrical supply lines must be run through watertight conduit. Run the wires and conduit from the power source and connect them to the conduit connection labeled “High Voltage Connection” on the right side of the heat pump. See Figure 11 for connection location.

5. Connect the wires to the terminals on the main contactor as shown in the wiring diagrams. Refer to Figures 8 and 9.
6. Connect the ground wire to the ground lug provided in the electrical compartment.
7. Replace the cover of the junction box.
8. Replace the service access panel and replace the screws to hold it in place.
9. Connect a copper bonding wire (8 ga) to the bonding lug on the right side of the heat pump.

### 4.3 Bonding

#### WARNING

**ELECTRICAL SHOCK HAZARD.** This heat pump contains wiring that carries high voltage. Contact with these wires may result in severe injury or death. Disconnect power circuit before connecting the heat pump

#### AVERTISSEMENT

**POSSIBILITÉ DE CHOCS ÉLECTRIQUES.** Ce système de chauffage contient du filage de haut voltage. Un contact avec ces fils peut résulter en des blessures sérieuses ou la mort. Débranchez le circuit de puissance avant de relier la pompe à chaleur

#### AVISO

**PELIGRO DE DESCARGA ELÉCTRICA.** Esta bomba de calor, contiene cableado de alta tensión. El contacto con los cables podría ocasionar lesiones graves o la muerte. Desconecte el circuito de alimentación, antes de conectar la bomba de calentar.

#### CAUTION

Label all wires prior to disconnection when servicing controls. Wiring errors can cause improper and dangerous operation. Verify proper operation after servicing.

#### ATTENTION

Au moment de l'entretien des commandes, étiquetez tous les fils avant de les débrancher. Des erreurs de câblage peuvent entraîner un fonctionnement inadéquat et dangereux.

#### PRECAUCIÓN

Proceda a etiquetar todos los cables antes de su desconexión en los controles de mantenimiento. Los errores de cableado pueden ocasionar un funcionamiento peligroso e inadecuado. Comprobar que el funcionamiento es correcto, una vez efectuado el mantenimiento.

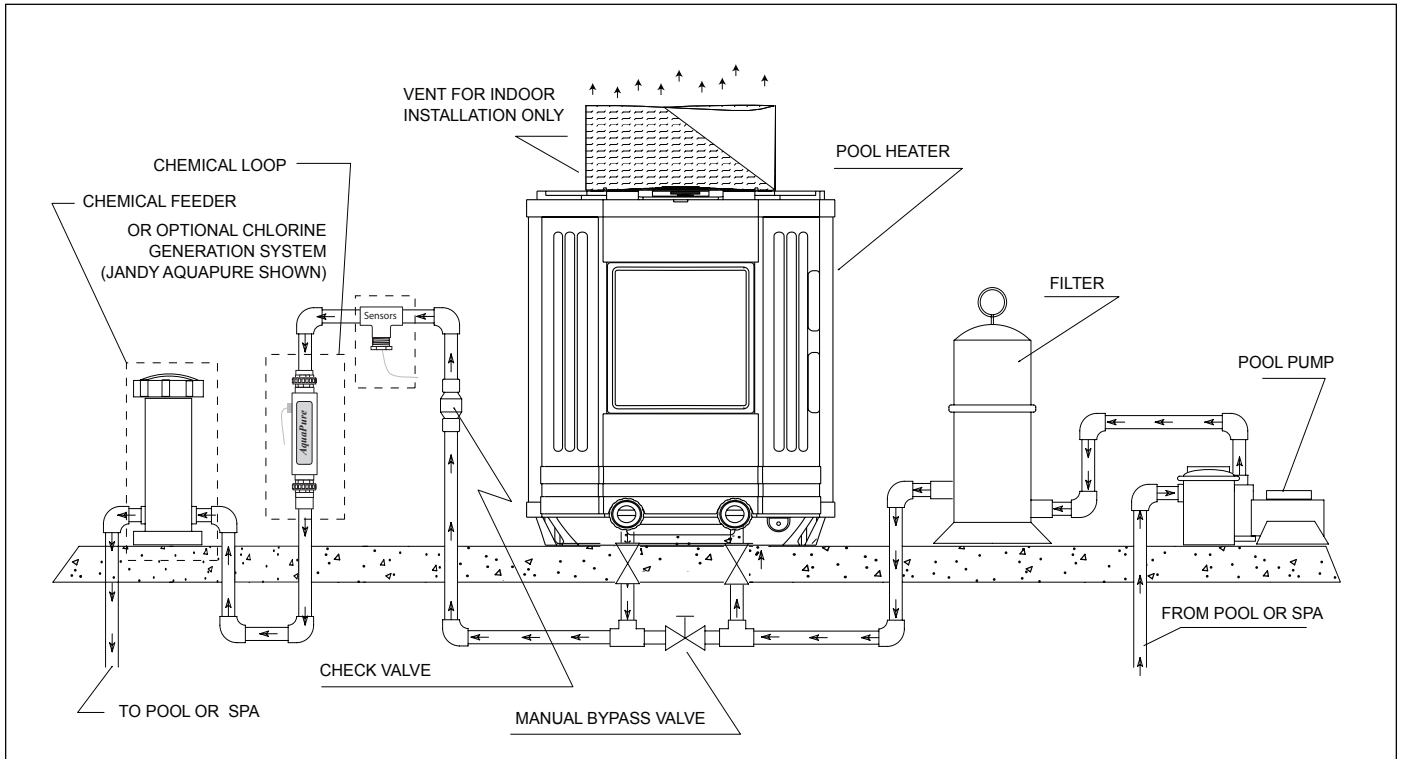

Figure 4. Standard Plumbing Layout

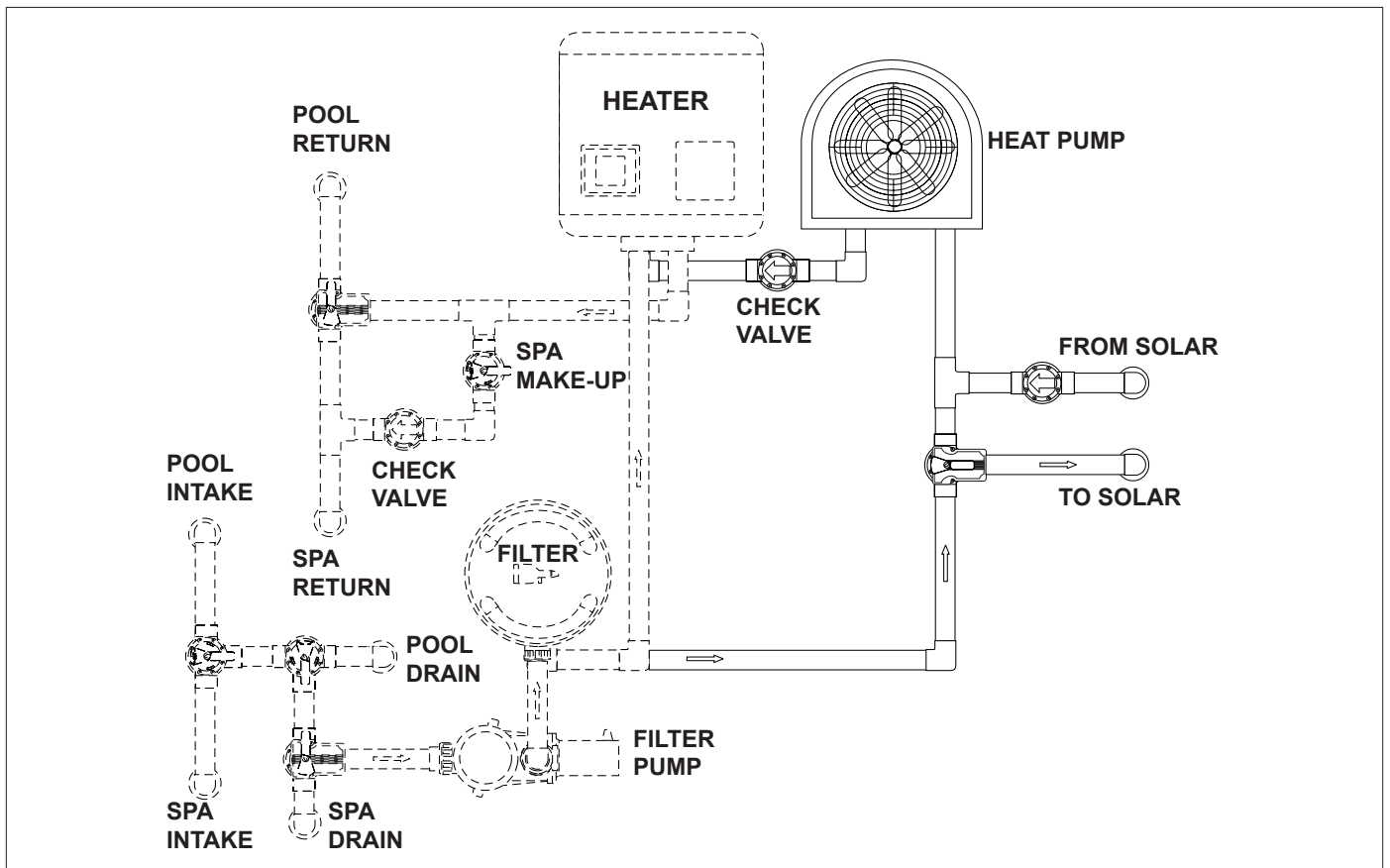

Figure 5. Plumbing For Heating System Combinations

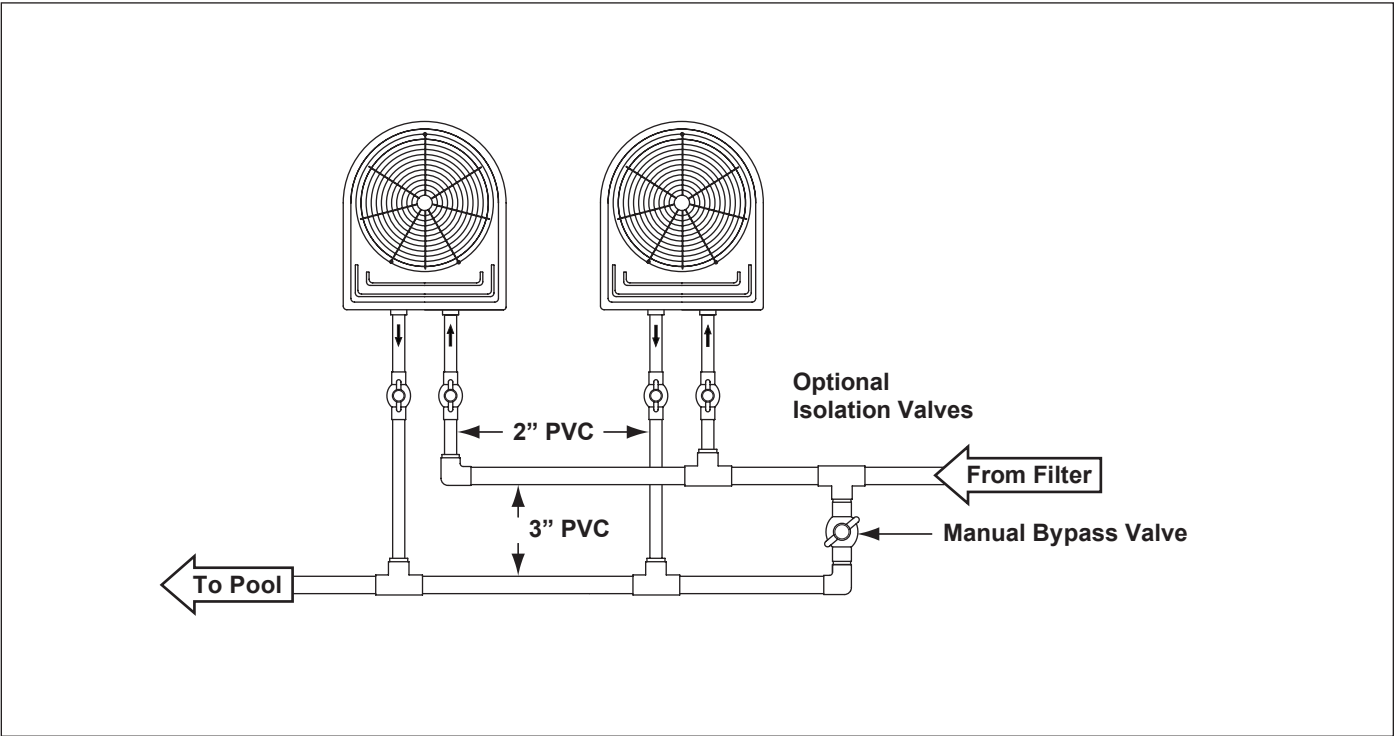

Figure 6. Two Heat Pump Plumbing Layout

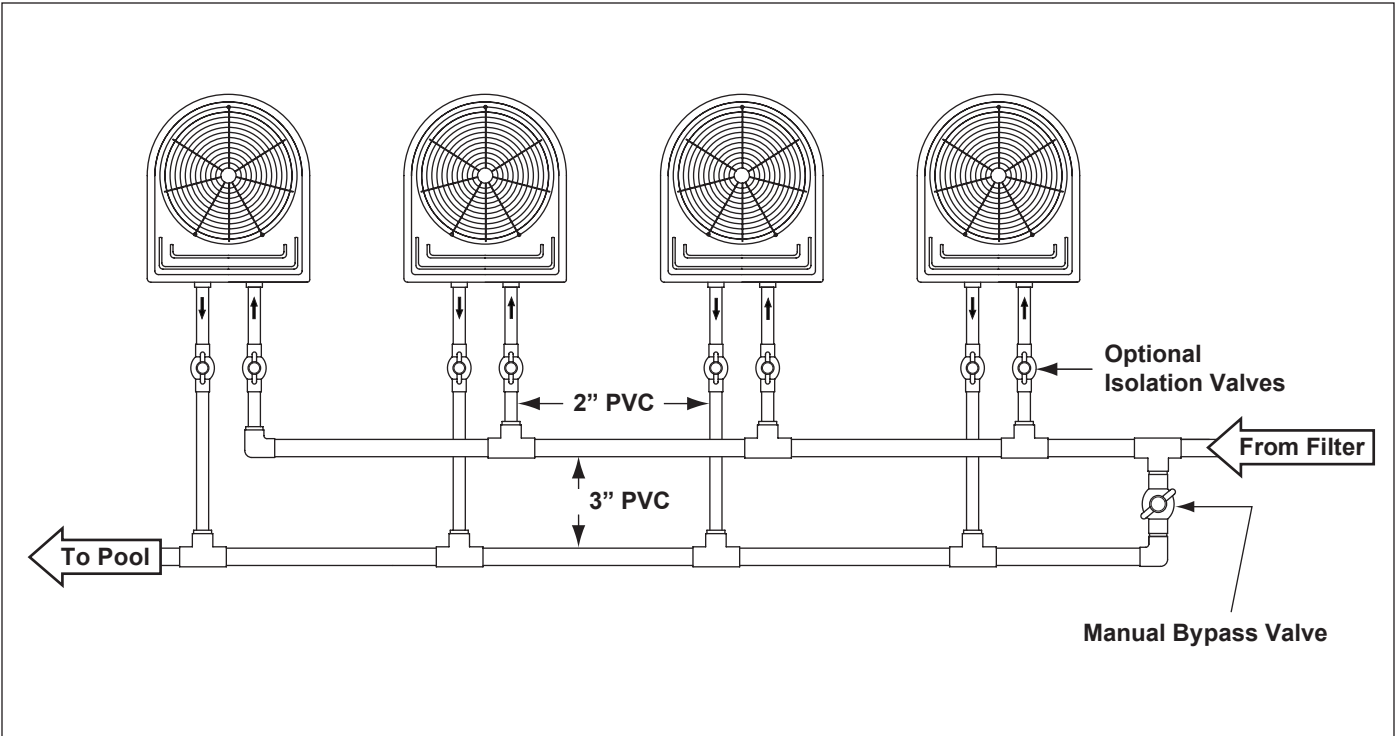

Figure 7. Four Heat Pump Plumbing Layout

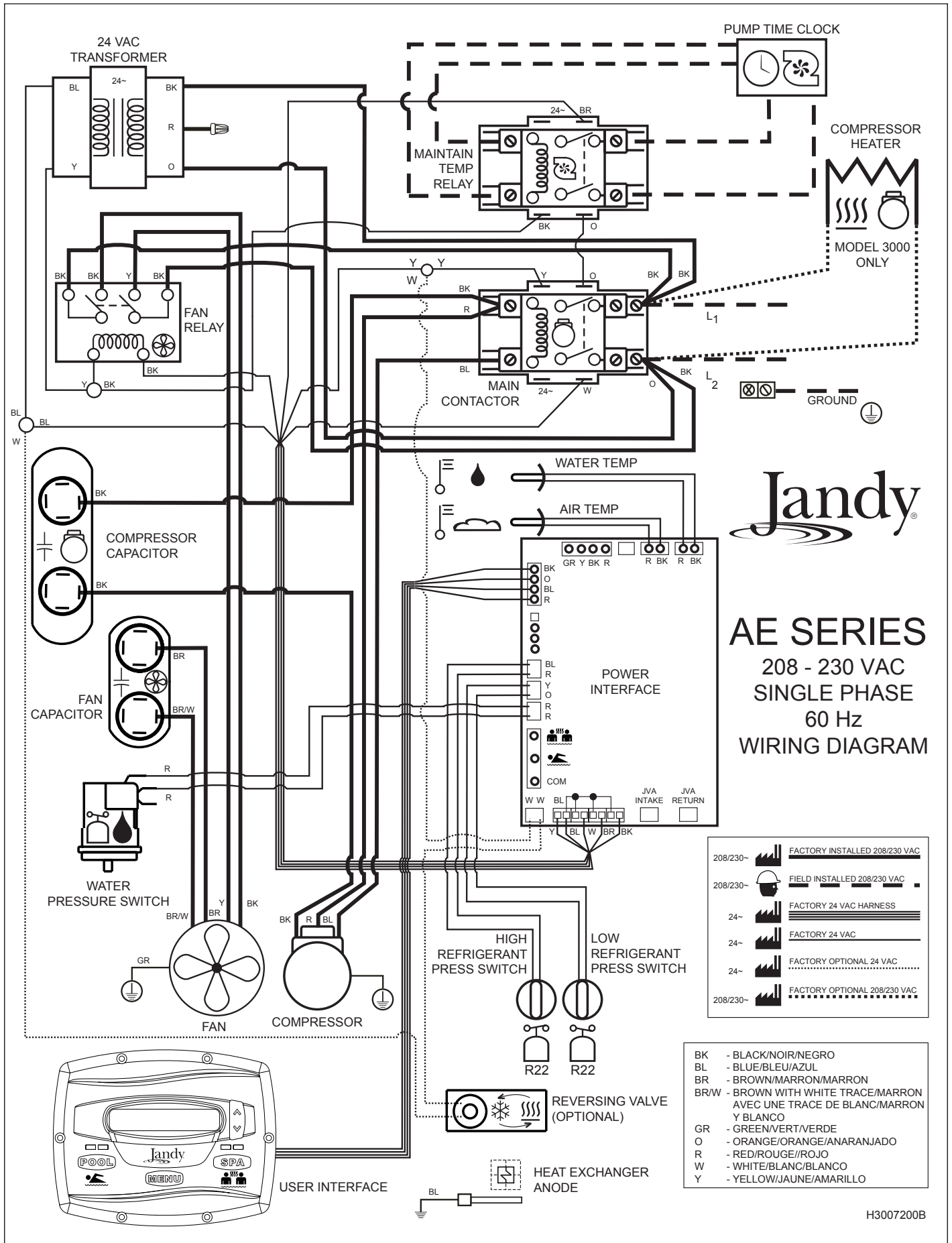

Figure 8. AE-Ti Single-Phase Electrical Supply Wiring Diagram

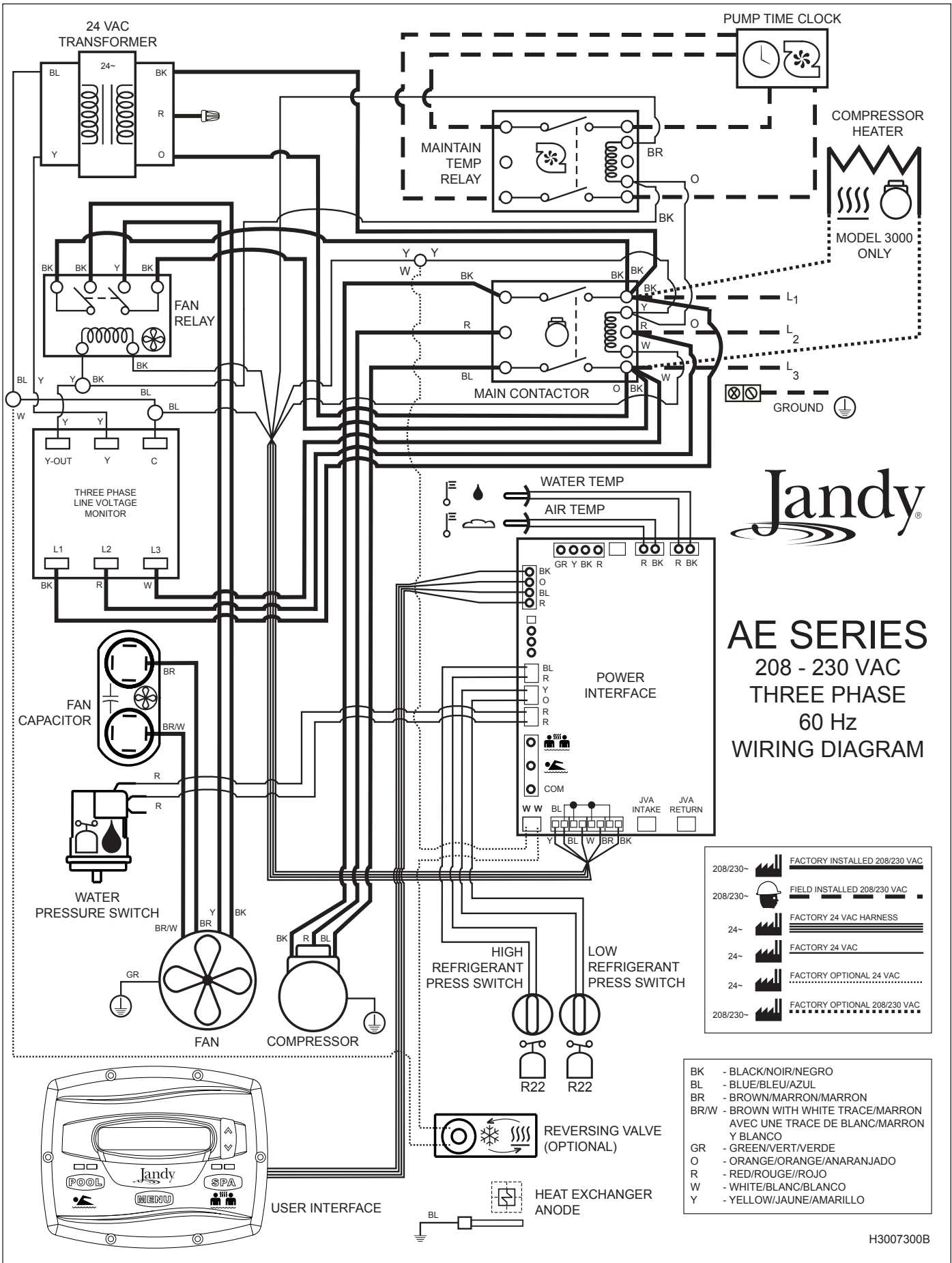
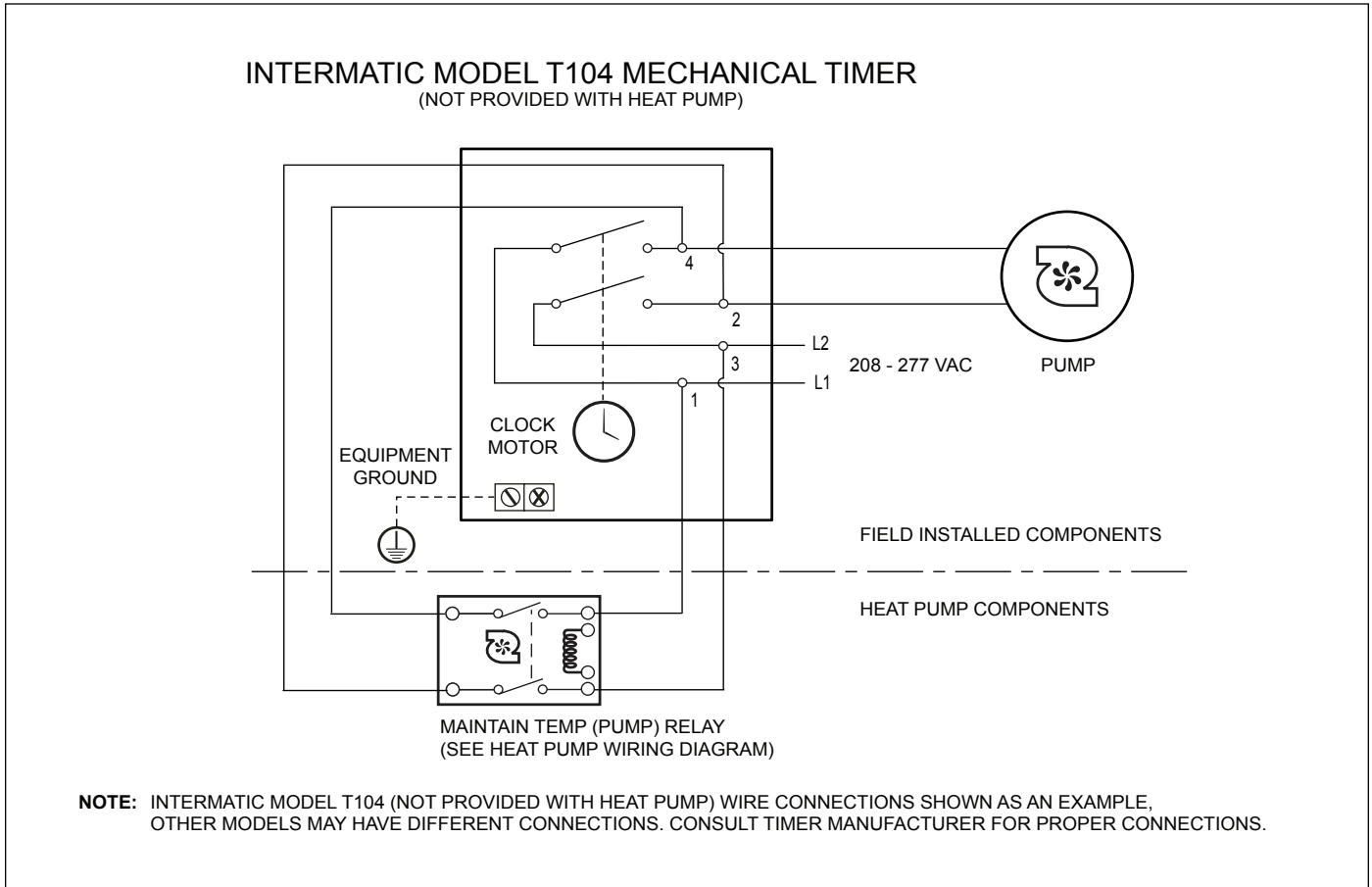

Figure 9. AE-Ti 3-Phase Electrical Supply Wiring Diagram

H3007300B





**Figure 10. Example of “MAINTAIN TEMP” Wiring to the Time Clock**

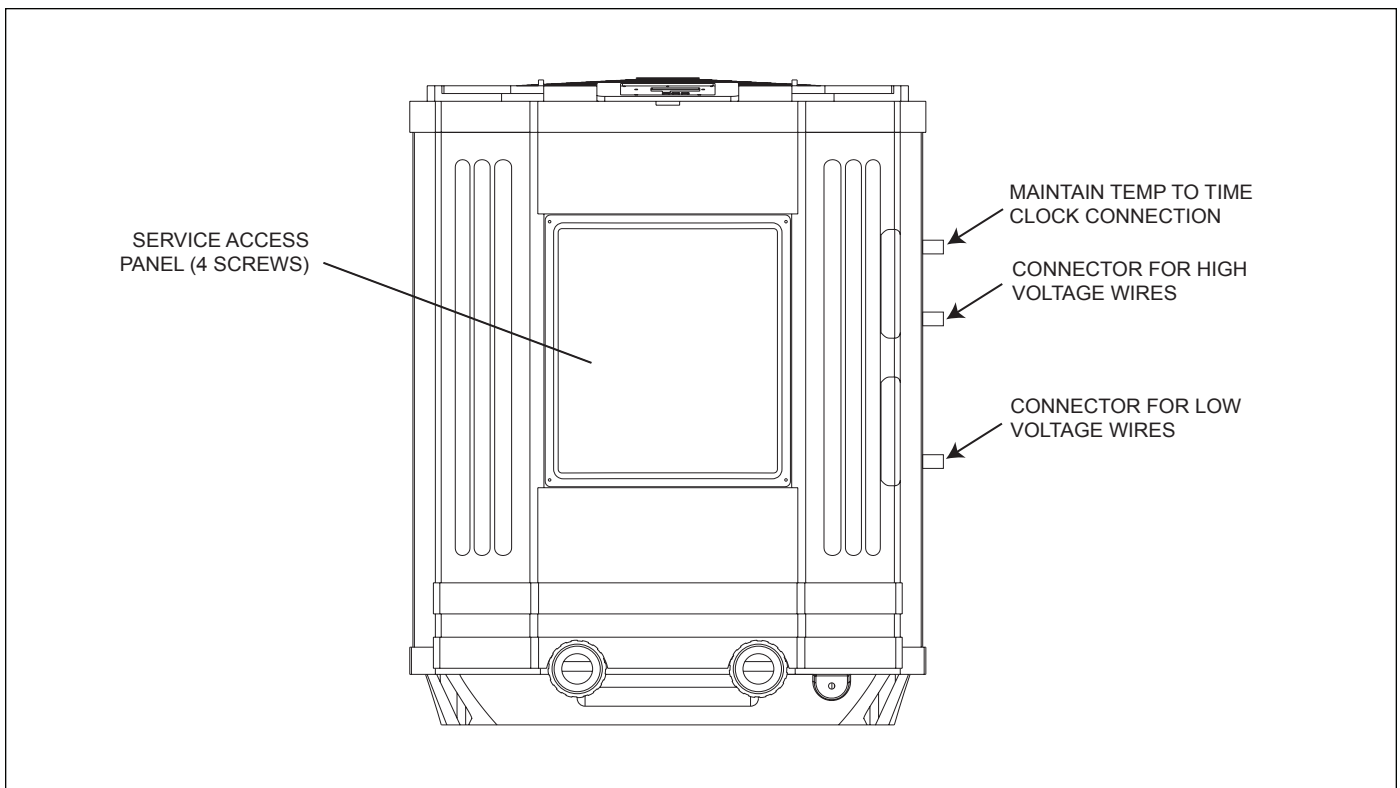

**Figure 11. AE-Ti Heat Pump Front View**

**⚠ CAUTION**

This heater must be connected to a bonding grid with a solid copper wire not smaller in diameter than 8 ga (In Canada, it shall be no smaller than 6 ga.)

**⚠ ATTENTION**

L'appareil de chauffage doit être connecté à une grille de mise à la terre par un fil de cuivre d'un diamètre de calibre minimal 8. (Au Canada, cela ne devrait pas être inférieur à 6 ga.)

**⚠ PRECAUCIÓN**

Esta bomba de calor deberá estar conectada a una rejilla de unión con hilo de cobre sólido, de un diámetro no inferior a 8 ga. (En Canadá, no será más pequeño de 6 ga.)

The National Electrical Code and most other U.S. codes require that all metallic components of a pool structure, including reinforcing steel, metal fittings, and above ground equipment be bonded together with a solid copper conductor not smaller than 8 ga. The heat pump, along with pumps and other pool equipment must be connected to this bonding grid. A bonding lug is provided on the right hand side of the heat pump to ensure this requirement is met.

#### 4.4 Pump Connection (Maintain Temp Feature)

This feature allows the heat pump to turn on the pool pump, bypassing the time clock setting, to maintain the desired temperature. In order for the **MAINTAIN TEMP** feature to be functional, a dedicated line from the pool pump time clock to the Maintain Temp (Pump) Relay is needed. See Figure 10.

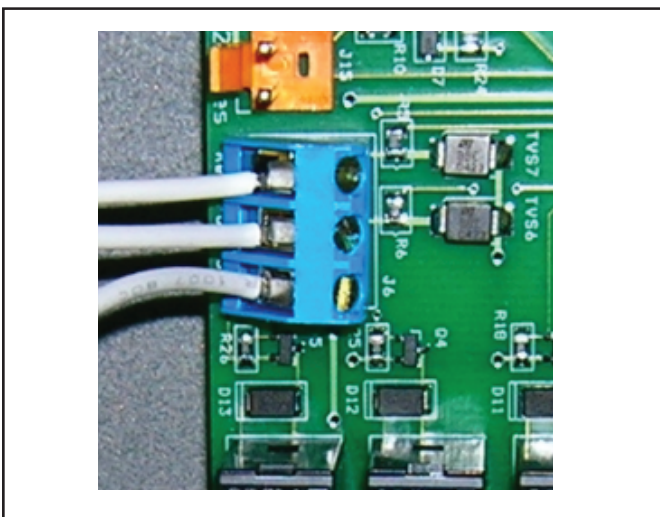

Figure 12a. Remote Pool-Off-Spa Connection (3-Wire Connection)

#### 4.5 Optional Remote Controls

Electrical wiring must be in accordance with all applicable national and local codes and ordinances.

##### 4.5.1 Connection to a Remote Pool-Off-Spa Selector (3-Wire Connection)

###### 4.5.1.1 Install the Remote Pool-Off-Spa Selector

1. Turn off the power to both the pool/spa control system and the heat pump unit.
2. Remove the screws that attach the service/access panel to the heat pump unit and the cover to the junction box (see Figure 11).
3. Run the wires from the pool/spa control system into the conduit connection labeled “Low Voltage Connection”, located on the lower right hand side of the heat pump (see Figure 11).
4. Connect the wiring from the pool/spa control system to the heat pump remote control terminal (see Figure 12a).
5. Restore power to the heat pump and the pool/spa control system.

###### 4.5.1.2 Configure the Control Panel

1. Make sure the control is in the **OFF** mode.
2. To enter the Service Setup mode, press and hold the **MENU**, **POOL**, and **SPA** buttons for 5 seconds.

**NOTE** The display will revert back to **OFF** after one minute since the last key press.

3. Press the **Up** or **Down** button to display **REMOTE**. Press the **MENU** button. The **SELECT REMOTE OFF** (default remote) appears, use the **Up** or **Down** button to scroll through the Remote

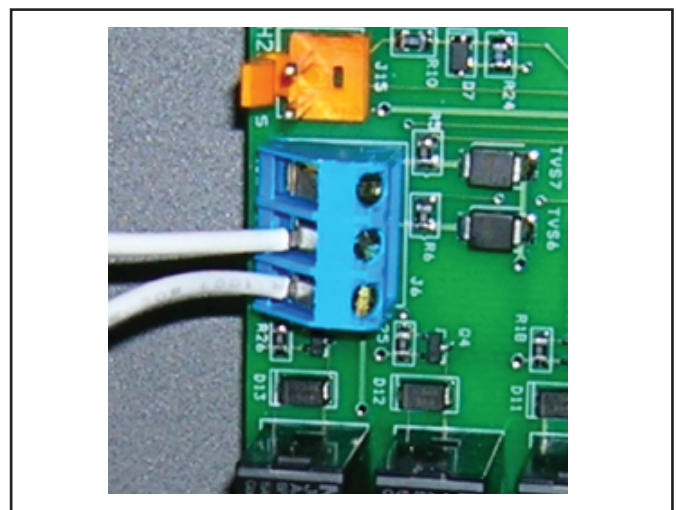

Figure 12b. AquaLink RS or Remote TSTAT Connection (2-Wire Connection)

options. When you reach **HI-LO-COM**, press the **MENU** button to select the remote. Press **POOL** or **SPA** to exit the Service Setup mode.

#### 4.5.2 Two-Wire Connection to an AquaLink® RS or TSTAT

##### 4.5.2.1 Configure the AquaLink® RS Control System

1. Turn off the power to both the pool/spa control system and the heat pump unit.
2. Connect two wires to the AquaLink RS green 10-pin terminals 1 and 2.
3. Put DIP S2-1 (pin #1 of the 4 position DIP switch) into the ON position (see Figure 13).

##### 4.5.2.2 Install the Remote TSTAT

1. Turn off the power to both the pool/spa control system and the heat pump unit.
2. Remove the screws that attach the service/access panel to the heat pump unit and the cover to the junction box (See Figure 11).
3. Run the wires from the pool/spa control system into the conduit connection labeled “low voltage connection”, located on the lower right hand side of the heat pump (See Figure 11).
4. Connect the wiring from the pool/spa control system to the heat pump remote control terminal (See Figure 12b).

5. Restore power to the heat pump and the pool/spa control system.

##### 4.5.2.3 Configure the Control Panel

1. Make sure the control is in the **OFF** mode.
2. To enter the Service Setup mode, press and hold the **MENU**, **POOL**, and **SPA** buttons for 5 seconds.

**NOTE** The display will revert back to **OFF** after one minute since the last key press.

3. Press the **Up** or **Down** button to display **REMOTE**. The **SELECT REMOTE OFF** (default remote) appears, use the **Up** or **Down** button to scroll through the Remote options. When you reach **REMOTE TSTAT**, press the **MENU** button to select the remote. Press **POOL** or **SPA** to exit the Service Setup mode.
4. Press **SPA**. For heating, adjust the setpoint to the maximum setting. For chilling, adjust the setpoint to the minimum setting.

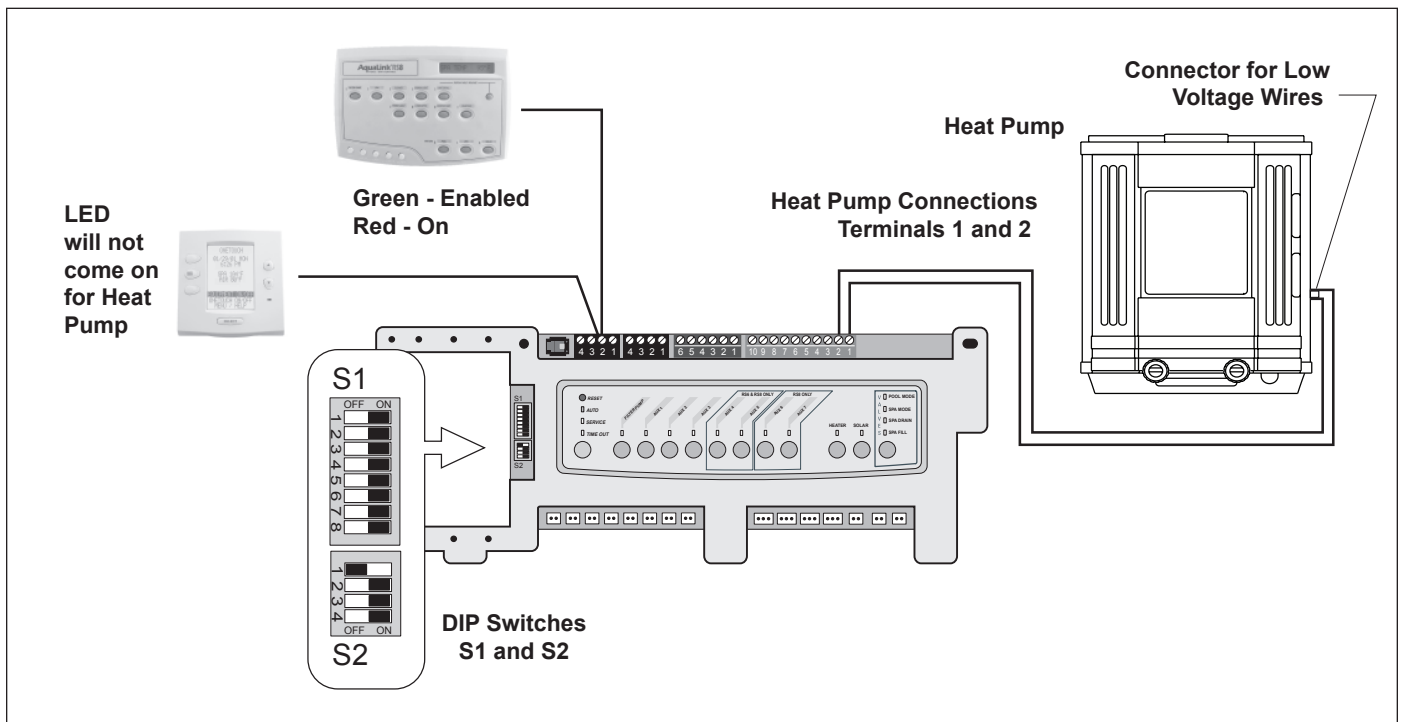

Figure 13. AquaLink RS to AE-Ti Heat Pump

### 4.5.3 Four-Wire Connection to AquaLink® RS 485 Communication

1. Confirm the AE-Ti heat pump and AquaLink RS software revisions are compatible (see Figure 14).

**NOTE** Only a revision "N", or higher, program chip in the RS system will support the AE-Ti heat pump interface.

2. Turn off the power to both the heat pump and the RS control and open the RS Power Center enclosure and remove the front dead panel.
3. Remove the two screws holding the bezel in place and turn the bezel over to view the circuit board on the back.
4. Locate the programmed chip on the Power Center Board. In the center of the chip is the revision letter. If the revision letter is "N" or higher go to step 5. If the revision level is "MMM" or lower, replace the board.
5. Use 22 gauge 4-conductor wire (Jandy Part No. 4278) to run between the heat pump and the RS control, and match the wire color order.
6. The wires coming from the AE-Ti heat pump can be "doubled up" on the red terminal bar with the four wires coming from the indoor controller.

**NOTE** If you need to install more than two wires in each terminal, order a Jandy Multiplex PCB Kit, which includes the Multiplex Board (Jandy Part No. 6584). Never put more than two wires into each of the pins of the terminal bar.

7. Check all wiring, then apply power to both the heat pump and the RS control system. Operation can be verified in either Service or Auto mode. See the RS Control System manual for instructions about operation.

When the AE-Ti heat pump is first powered and there is an RS control connected to the heat pump, the display on the heat pump will show **"JANDY REMOTE ONLINE PUSH MENU TO DISABLE"**. When the AE-Ti heat pump is online with the RS control, all functionality of the control on the heat pump is disabled. The heat pump functions can be controlled only at the RS unit.

To temporarily use the heat pump controls, press the **MENU** button. The message **"JANDY REMOTE ONLINE PUSH MENU TO DISABLE"** will disappear from the heat pump display. All functionality has now been returned to the control on the heat pump. In this mode the RS unit is no longer controlling the heat pump.

To return the functionality to the RS unit, cycle (turn off and then turn on) the power to the heat pump, or press the **MENU** button for 5 seconds to enter the User Setup Mode and then enable the Jandy Remote.

AE-Ti Heat Pump Power Interface Software Rev.	AquaLink RS Software Revision
3.0 or Later	N or Later

**NOTE** If connecting more than two (2) items to the RS Power Center red, 4-pin connector, a Multiplex PCB is required.

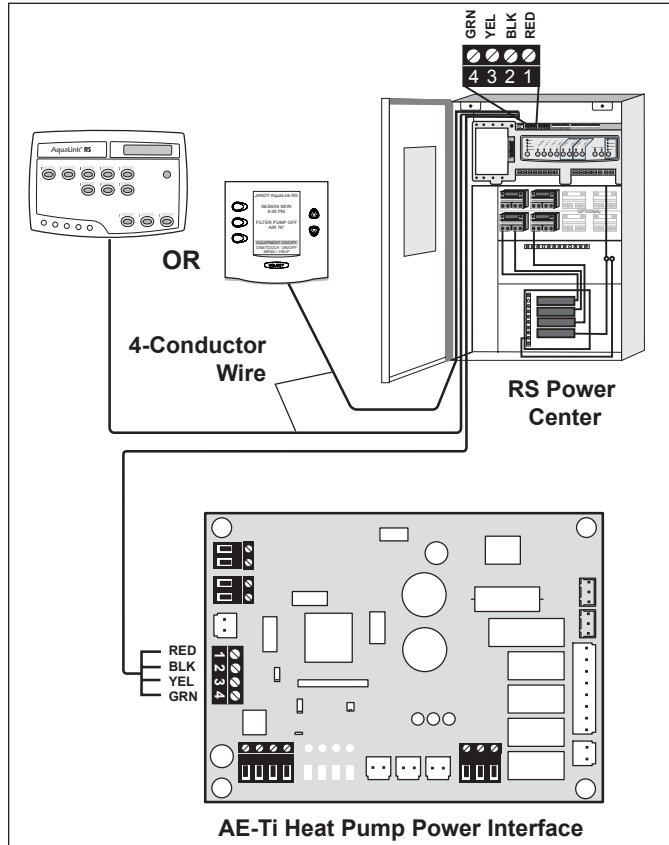

**Figure 14. AE-Ti Heat Pump Connection to Power Center**

### 4.5.4 Connection to a Secondary User Interface

1. Turn off the power to the heat pump.
2. Remove the four (4) screws that attach the service access panel to the heat pump and remove the cover to the junction box. See Figure 11.
3. Run four (4) 22 Ga solid copper wires into the conduit labeled "Low Voltage Connection" located on the lower right hand side of the heat pump. See Figure 11. The wires may be up to 300 feet in length.
4. Connect the wires to the 4 position terminal on the upper left hand corner of the Power Interface PC Board, labeled "User Interface1". The wires will be added to the existing wiring to the User Interface installed on the heat pump.

5. Ensure the wiring is consistent when connecting the wires to the second User Interface. For example, BK goes to BK, O goes to O, etc.
6. Re-install the junction box cover and service access panel and restore power to the heat pump.

## Section 5. Operation

### ⚠ CAUTION

Do not use this heat pump if any part has been under water. Immediately call a qualified service technician to inspect the heater and replace any part of the control system which has been under water.

### ⚠ ATTENTION

N'utilisez pas cet appareil s'il a été plongé dans l'eau, même partiellement. Faites inspecter l'appareil par un technicien qualifié et remplacez toute partie du système de contrôle et toute commande qui ont été plongés dans l'eau.

### ⚠ PRECAUCIÓN

No utilice esta bomba de calor si algunos de sus componentes han estado debajo del agua. Póngase inmediatamente en contacto con un técnico de mantenimiento cualificado para que inspeccione el equipo y reemplace cualquier parte del sistema de control que haya estado debajo del agua.

### ⚠ CAUTION

Keep all objects off the top of the heat pump. Blocking air flow could damage the unit and may void the warranty.

### ⚠ ATTENTION

Ne posez aucun objet sur le dessus de l'appareil. Il pourrait empêcher la circulation de l'air, ce qui risquerait d'endommager l'appareil et d'annuler la garantie.

### ⚠ PRECAUCIÓN

Mantenga todos los objetos fuera de la parte superior de la bomba de calor. La obstrucción del flujo de aire podría dañar la unidad y anular la garantía.

### 5.1 Initial Start-up Precautions

Be sure that there is water in the pool and that the surface level is above the skimmer or other inlet of the

pool's filter system.

With any new pool or spa installation, operate the filter pump with the heat pump off long enough to completely clean the water. This will remove any installation residue from the water.

Clean the filter at the end of this operation before starting the heat pump. When raising the temperature of a cold pool, program the time clock to run the pump continuously.

This lets the filter system and heat pump operate continuously until the water reaches the temperature setting on the temperature control. When that happens, the heat pump will automatically shut off, but the filter pump will keep running.

## 5.2 Operating the Controller

Your new AE-Ti heat pump is controlled by an advanced microprocessor based controller that provides a sophisticated yet simple interface to operate your heat pump for maximum efficiency and enjoyment of your pool. To locate the control buttons, see Figure 15.

### 5.2.1 Off Mode

When the control panel is turned off, the screen displays **HEAT PUMP IS OFF PRESS POOL OR SPA**.

### 5.2.2 Pool Mode - (Normal Heat)

To enable the pool mode, press **POOL**. The associated left green LED indicator will light and the unit will display **SET:XXX°**.

**NOTE** *XXX* represents the current temperature setting on the control. The default setting for pool temperature is 80°F (26°C).

You can change the temperature set point by pressing the **Up** or **Down** button. Repeatedly press the **Up** or **Down** button until you reach the desired temperature set point. After 5 seconds of inactivity, the new set point is stored in memory.

When the water temperature falls to 1 degree below the temperature setting *and* after a 5 minute delay, the control will start the heat pump and the associated right LED will light RED.



Figure 15. Main Control Panel

### 5.2.3 Pool Mode - (Optional Maintain Heat)

If connected, the Maintain Heat mode allows the heat pump to monitor the temperature of the water 24 hours a day by turning the pool pump on and sampling the water temperature.

A Maintain Temp Relay is required (provided) and the feature must be enabled.

When the water temperature drops below the programmed temperature set point, the control will start the heat pump.

To operate in pool mode with the Maintain Heat feature, press **POOL**, then press **MENU**, press the **Down** button until **MAINTAIN POOL HEAT** is displayed, press the **MENU** button.

The associated left green LED indicator will light and the unit will display **SET:XXX°**. Change the temperature set point by pressing the **Up** or **Down** button until the desired set point is displayed. After 5 seconds of inactivity, the new set point is stored in memory.

### 5.2.4 Spa Mode - (Normal Heat)

To enable the spa mode, press **SPA**. The associated left green LED indicator will light and the unit will display **SET:XXX°**.

**NOTE** *XXX* represents the current temperature setting on the control. The default setting for spa temperature is 102°F (38°C).

You can change the temperature set point by pressing the **Up** or **Down** button. Repeatedly press the **Up** or **Down** button until you reach the desired temperature set point. After 5 seconds of inactivity, the new set point is stored in memory. When the water temperature falls to 1 degree below the temperature setting *and* after a 5 minute delay, the control will start the heat pump and the associated right LED will light RED.

### 5.2.5 Spa Mode - (Optional Maintain Heat)

If connected, the Maintain Heat mode allows the heat pump to monitor the temperature of the water 24 hours a day by turning the spa pump on and sampling the water temperature.

A Maintain Temp Relay is required (provided) and the feature must be enabled.

To operate in spa mode with the Maintain Heat feature, press **SPA**, then press **MENU**, press the **Down** button until **MAINTAIN SPA HEAT** is displayed, press the **MENU** button. The associated left green LED indicator will light and the unit will display **SET:XXX°**. Change the temperature set point by pressing the **Up** or **Down** button until the desired set point is displayed. After 5 seconds of inactivity, the new set point is stored in memory.

## 5.3 Operating Features of Hybrid Units with Optional Chiller

**NOTE** The chiller is an optional equipment. Not all units are provided with chiller.

### 5.3.1 Pool Mode - (Normal Chill)

To enable the pool mode, press **POOL**. The associated left green LED indicator will light and the unit will display **SET:XXX°**.

**NOTE** *XXX* represents the current temperature setting on the control. The default setting for pool temperature is 80°F (26°C).

Press the **MENU** button. Press the **Up** or **Down** button until you reach **POOL CHILL**, press the **MENU** button.

**NOTE** **POOL CHILL** will not be displayed if the unit is not provided with chiller.

You can change the temperature set point by pressing the **Up** or **Down** button. Repeatedly press the **Up** or **Down** button until you reach the desired temperature set point. After 5 seconds of inactivity, the new set point is stored in memory. When the water temperature rises to 1 degree above the temperature setting *and* after a 5 minute delay, the control will start the heat pump and the associated right LED will light GREEN.

### 5.3.2 Pool Mode - (Optional Maintain Chill)

If connected, the Maintain Chill option mode allows the unit to monitor the temperature of the water 24 hours a day by turning the pool pump on and sampling the water temperature.

A Maintain Temp Relay is required (provided) and the feature must be enabled.

When the temperature of the water rises above the desired temperature setting, the control will then turn on the unit and the associated right green LED will light.

To operate in pool mode with the Maintain Chill feature, press **POOL**, then press **MENU**, then press the **Down** button until **MAINTAIN POOL CHILL** is displayed, press the **MENU** button. The associated left green LED indicator will light and the unit will display **SET:XXX°**. Change the temperature set point by pressing the **Up** or **Down** button until the desired set point is displayed. After 5 seconds of inactivity, the new set point is stored in memory.

### 5.3.3 Spa Mode - (Optional Maintain Chill)

If connected, the Maintain Chill mode allows the heat pump to monitor the temperature of the water 24 hours a day by turning the spa pump on and sampling the water temperature.

A Maintain Temp Relay is required (provided) and the feature must be enabled.

When the water temperature rises above the programmed temperature set point, the control will start the heat pump.

To operate in the spa mode with the Maintain Chill feature, press **SPA**, then press **MENU**, press the **Down** button until **MAINTAIN SPA CHILL** is displayed, press the **MENU** button. The associated left green LED indicator will light and the unit will display **SET:XXX°**. Change the temperature set point by pressing the **Up** or **Down** button until the desired set point is reached. After 5 seconds of inactivity, the new set point is stored in memory.

## 5.4 User Setup Options

The User Setup options allow the user to select specific Languages, Temperature Scale, Spa Timer, and Display Light options.

### 5.4.1 Language Setup

1. Make sure the control is in the **OFF** mode.
2. To enter the User Setup mode, press and hold the **MENU** button for 5 seconds.

**NOTE** The display will revert back to **OFF** after one minute since the last key press.

3. To select a language, use the **Up** or **Down** button to display **SELECT USER SETUP LANGUAGE**. Press the **MENU** button. The **SELECT LANGUAGE ENGLISH** (default language) appears, use the **Up** or **Down** button to scroll through the language options. When you reach the desired language, press the **MENU** button to select the language. Press **POOL** or **SPA** to exit the User Setup mode.

### 5.4.2 Temperature Scale Setup

1. Make sure the control is in the **OFF** mode.
2. To enter the User Setup mode, press and hold the **MENU** button for 5 seconds.
3. To select temperature scale, use the **Up** or **Down** button to scroll through to display **SELECT USER SETUP TEMPERATURE SCALE**. Press the **MENU** button. The **SELECT TEMP SCALE °F** (default temperature scale) appears, use the **Up** or **Down** button to scroll through the scale options. When you reach the desired temperature scale, press the **MENU** button to select. Press **POOL** or **SPA** to exit the User Setup mode.

### 5.4.3 Spa Timer Setup

1. Make sure the control is in the **OFF** mode.
2. To enter the User Setup mode, press and hold the **MENU** button for 5 seconds.

3. To select spa timer, use the **Up** or **Down** button to scroll through to display **SELECT USER SETUP SPA TIMER**. Press the **MENU** button. The **SELECT SPA TIMER CONTINUOUS** (default spa timer setting) is displayed. To turn the spa on or off indefinitely, press the **MENU** button to select.

To select the length of time for the spa to run, use the **Up** or **Down** button to scroll to display **SELECT SPA TIMER TIME SELECTION**. Press the **MENU** button to select. The display **SELECT SPA TIME 01:00 HRS** (default time setting) is displayed. Use the **Up** or **Down** button to select the length of time for the spa to run (between 00:15 to 23:00 hours incremented by 00:15 minutes). Press the **MENU** button to select how long the spa will run. Press **POOL** or **SPA** to exit the User Setup mode.

### 5.4.4 Display Light Setup

1. Make sure the control is in the **OFF** mode.
2. To enter the User Setup mode, press and hold the **MENU** button for 5 seconds.
3. To select display light setup, use the **Up** or **Down** button to scroll through to display **SELECT USER SETUP DISPLAY LIGHT**. Press the **MENU** button. The **SELECT DISPLAY LIGHT 2 MIN TIMEOUT** (default display light setting) is displayed. This option allows the display light to turn off after 2 minutes. Press the **MENU** button to select. Use the **Up** or **Down** button to scroll to display **SELECT DISPLAY LIGHT LIGHT OFF**, this option allows the display light to turn off, press the **MENU** button to select. Use the **Up** or **Down** button to scroll to display **SELECT DISPLAY LIGHT LIGHT ON**, this option allows the display light to turn on, press the **MENU** button to select. Press **POOL** or **SPA** to exit the User Setup mode.

## 5.5 Set Point Lockout

Make sure the control is in the **ON** mode (**POOL** or **SPA**), press and hold the **Up** and **Down** buttons for 5 seconds. The set point will be locked and the control will operate in the mode it was in when the Set Point Lockout occurred. If an attempt to change the set point is made while the control is in Set Point Lockout, the control will display **SET POINT LOCKED**. To unlock the Set Point Lockout, press and hold the **Up** and **Down** buttons for 5 seconds. The unit will display **SET POINT UNLOCKED**.

## 5.6 Water Pressure Switch Adjustment

### CAUTION

The water pressure switch should be adjusted to turn the heater off when the pump is off. Setting the switch to close at too low of a flow can damage the appliance. Adjust the switch to turn the heater off, not on.

### ATTENTION

Le manoccontact de pression d'eau doit être réglé de façon à ce que l'appareil cesse de fonctionner si la pompe s'arrête. Si le manoccontact est réglé pour se fermer lorsque le débit d'eau est trop faible, l'appareil risque de s'endommager. Réglez le manoccontact pour qu'il arrête l'appareil, et non pour qu'il le mette en marche.

### PRECAUCIÓN

El interruptor de la presión del agua, deberá ajustarse de forma que el calentador se apague cuando se apague la bomba. La calibración del interruptor para que pueda apagarse con flujos demasiado bajos podría estropear el equipo. Ajuste el interruptor para apagar el calentador, no para encenderlo.

The pressure switch is preset at the factory for activation at 2 psi (14 kPa). This is the minimum setting for the water pressure switch and works for all basic installations as shown previously in Section 3.1 and Section 3.5 in this manual. Only adjust the water pressure switch if the heat pump does not operate *when the proper flow is applied to unit* or if the heat pump does not shut off when the filter pump is off. Occasionally, unusual plumbing configurations or necessary restrictions in the plumbing may cause pressure sensing problems. In these rare situations, the plumbing system configuration may require adjustment of the water pressure switch.

Adjustment of the pressure switch may be necessary if any part of the filter system piping is 3 feet (1 m) or more above the top of the heat pump jacket.

Do not adjust the pressure switch if the heat pump is installed more than 11 feet (3,5 m) above or 5 feet (1,5 m) below the pool surface. Consult your local Jandy dealer for recommendations.

On some installations, the piping from the heat pump to the pool is very short. The back pressure could be too low to trigger the pressure switch. If this happens, it may be necessary to install a directional fitting or elbows where the return line enters the

pool. This will increase back pressure enough for the heat pump to operate properly. If this configuration is necessary, be sure to check that the system flow is above the minimum requirement of 30 gpm after the direction fitting or elbow has been installed.

Make sure the pool filter is clean before making any pressure switch adjustment: A dirty filter will restrict the water flow and the pressure switch cannot be adjusted properly.

To adjust the pressure switch:

1. Be sure that all valves in the system are set to allow water flow through the heat pump. Start the filter pump.
2. Set the heat pump control to call for heat. Set the heat pump control to the POOL HEAT mode.
3. If the heat pump control displays "NO FLOW", then the flow in the system may be below the minimum flow of 30 gpm needed for the safe operation of the heat pump. Investigate and correct any flow problems before adjusting the water pressure switch.
4. Remove the heat pump's control access panel. The water pressure switch is located in the lower left corner of the control compartment.
5. After confirming the flow rate is at a minimum of 30 gpm, slowly rotate the thumb wheel on the water pressure switch in a **counterclockwise** direction until the "NO FLOW" indicator disappears from the control display. Remember that there is a time delay before the heat pump compressor will start.
6. Once the heat pump is running, turn off the filter pump. The heat pump should turn off immediately.
7. If the heat pump continues to operate when the filter pump is off, turn the thumb wheel on the water pressure switch in a **clockwise** direction until "NO FLOW" is displayed on the control and the heat pump shuts down.
8. Check the setting of the water pressure switch by starting and stopping the filter pump and checking the control display and operation of the heater between each flow change.
9. If the water pressure switch cannot be adjusted to accommodate the conditions listed above, an external flow switch must be added to the plumbing system to ensure that the heat pump will not operate without the proper flow through the heat exchanger.



## Section 6. General Maintenance

### 6.1 Water Chemistry

Proper chemical balances are necessary for sanitary bathing conditions as well as ensuring your heat pump's long life. Be sure to keep your chemical and mineral concentration levels within the values indicated in Table 3.

**NOTE** For spas, it is also necessary to perform water changes in addition to chemical treatment. It is recommended to change the spa water every 60 days for light usage and every 30 days if usage is heavy.

### 6.2 Winterizing

**⚠ CAUTION**

Failure to winterize could cause damage to the heat pump and will void the warranty.

**⚠ ATTENTION**

La garantie sera annulée si l'appareil n'est pas hivernisé convenablement.

**⚠ PRECAUCIÓN**

La falta de acondicionamiento de la bomba de calor para el invierno podría causar daños y anular la garantía.

In areas where freezing temperatures occur, you should protect your pump, filter, and heat pump from the elements. Perform the following steps to completely drain the heat pump (see Figure 16).

1. Turn off the electrical power to the heat pump at the main breaker panel.
2. Shut off the water supply to the heat pump.

3. Disconnect the water inlet and outlet unions located on the lower front panel of the heat pump.
4. Open the drain located on the lower front panel of the heat pump to drain the remaining water from the heat exchanger. Leave the drain open until the unit is ready for seasonal start-up. Make sure all water has drained from the heat pump.
5. Cover only the top of the heat pump to prevent debris from falling into the unit. Do not wrap the sides of the heat pump with any plastic or other material that will retain heat or moisture inside the unit.

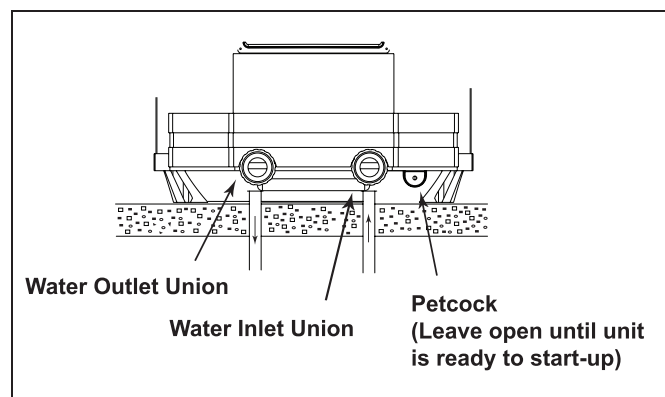

Figure 16. Winterizing the AE-Ti Heat Pump

Test	Recommended Level
Free Chlorine or Bromine	1.0 to 3.0 ppm
pH	7.2 to 7.8
Total Alkalinity (TA)	80 to 120 ppm
Calcium Hardness (CH)	175 to 400 ppm
Cyanuric Acid	50 to 75 ppm
Total Dissolved Solids (TDS)	1000 to 2000 ppm (Excluding dissolved NaCl from Salt Chlorine Generator)
Copper	0 ppm

\* Concentration levels taken from "Basic Pool and Spa Technology" published by APSP (Association of Pool and Spa Professionals).

Table 3. Optimal Water Chemistry Ranges

### 6.3 Spring Start-Up

If your heat pump has been winterized, perform the following steps when starting the system in the Spring:

1. Uncover the heat pump and inspect the top and sides for any debris or structural problems.
2. Close the petcock located on the lower front panel of the heat pump.
3. Connect the water inlet and outlet unions located on the lower front panel of the heat pump.
4. Turn on the filter pump to supply water to the heat pump. Circulate water through the system long enough to cycle all of the pool water through the filter. Check for leaks in and around the heat pump.
5. Check the pool chemistry and balance as necessary.
6. Turn on the electrical power to the heat pump at the main breaker panel.

### 6.4 Inspection and Service

Jandy Heat Pumps are designed and constructed to provide long performance life when installed and operated properly under normal conditions. Periodic inspections are important to keep your heat pump running safely and efficiently through the years.

#### 6.4.1 Owner Inspection

##### CAUTION

Do not use this heat pump if any part has been under water. Immediately call a qualified service technician to inspect the heater and replace any part of the control system which has been under water.

##### ATTENTION

N'utilisez pas cet appareil s'il a été plongé dans l'eau, même partiellement. Faites inspecter l'appareil par un technicien qualifié et remplacez toute partie du système de contrôle et toute commande qui ont été plongés dans l'eau

##### PRECAUCIÓN

No utilice esta bomba de calor si algunos de sus componentes han estado debajo del agua. Póngase inmediatamente en contacto con un técnico de mantenimiento cualificado para que inspeccione el equipo y reemplace cualquier parte del sistema de control que haya estado debajo del agua.

Jandy recommends that you inspect your heat pump on a regular basis and especially after abnormal weather conditions. The following basic guidelines are suggested for your inspection:

1. Keep the top and surrounding areas of the heat pump clear of all debris.
2. Keep all plants and shrubs trimmed and away from the heat pump.

The heat pump will produce condensation (water) while in operation. The heat pump base is designed to allow the condensation to exit through the bottom drain port when the unit is running. The condensation will increase as the outdoor air humidity level increases. Check the following at regular intervals to ensure proper condensate drainage:

1. Visually inspect and clear the bottom drain ports of any debris that could clog the ports.
2. Ensure that condensate water does not puddle inside the heat pump
3. Ensure that condensate run-off is properly directed away from the equipment pad to keep it from undermining the pad.

During normal operation, the heat pump produces three to five gallons of condensate per hour. If condensate drainage is above this range during operation or if water continues to drain from the base when the heat pump is not in operation for more than an hour, a leak in the internal plumbing may have occurred. Call a qualified heat pump technician to investigate the problem.

Keep the top air flow discharge and air flow intake area clear of debris so the air flow through the heat pump is not restricted. The cooler discharge air from the top should not accumulate and be drawn into the side air intake coils. Keep all plants and shrubs trimmed away from the heat pump.

Make sure the front of the unit is accessible for future service.

Keep lawn sprinkler heads from spraying on the heat pump to prevent corrosion and damage. Use a deflector if needed.

If the unit is installed under a very sharp roof pitch or under a roof without a gutter, a gutter or diverter should be fitted to prevent excessive water from pouring down into the unit.

### 6.4.2 Professional Inspection

Inspections performed at least once a year by a qualified technician are required to maintain your heat pump's safe and efficient operation. The following basic safety checks must be performed.

1. Check for loose or broken wires and terminal connections.
2. Verify the pressure switch operation. Turn the heat pump OFF. Disconnect the power to the pump time clock, or turn the pump time clock to an OFF position. Turn the heat pump back ON. The heat pump must not come on.
3. Inspect the electrical controls, specifically the following:
  - a. High and Low limits
  - b. Pressure switch
  - c. Temperature control
4. Inspect the evaporator coil for blockage and clean as necessary.
5. Check for spider webs or debris in the condensate drain; clean if necessary.
6. Conduct a normal operating cycle and observe that the unit operates properly.

## Section 7. Professional Maintenance and Service

### 7.1 Heat Pump Design

The Jandy Air Energy Heat Pump is one of the most efficient ways to heat a pool or spa. The heat pump transfers heat from the outside air to the pool or spa water by means of an internal heat exchanger.

When the fan is turned on, warm air is drawn through the refrigerant charged evaporator, turning the cold liquid refrigerant to a warm gas. The gas then flows through the compressor where it is compressed resulting in a much higher temperature.

The hot gas enters the heat exchanger where the water extracts the heat. The pump pulls in cool pool water, which in turn converts the hot gas back into a liquid refrigerant and starts the cycle over again.

**NOTE** The maximum heat output and efficiency of a heat pump is dependent upon the quality and performance of the major components used. Equally important are the environmental conditions (for example, air temperature, humidity, water temperature, and wind).

### 7.2 Heat Pump Components and Operation

**Evaporator** - As air passes through the evaporator, the refrigerant in the evaporator absorbs heat from the ambient air. The warmer the ambient air and the larger the surface area of the evaporator the more heat it can collect

**Fan** - The heat pump fan produces high volume airflow. Adequate airflow is required to move warm air through the large evaporator.

**Compressor** - The compressor compresses the refrigerant gas to a higher pressure, increasing the temperature.

**Heat Exchanger** - As the final step to the heating process, the heat exchanger transfers the heat from the hot gas to the water. (Also known as a condenser.)

**Reversing Valve** - (For Hybrid Units with Optional Chiller and Hot Gas Defrost) The reversing valve reverses the flow of the refrigerant, which results in transferring cold gas to the water, thus lowering the temperature.

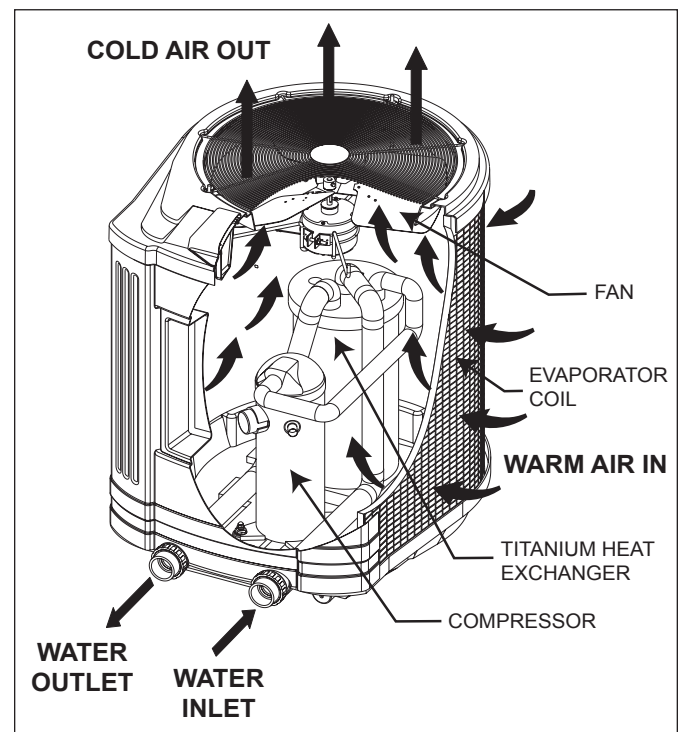

Figure 17. Heat Pump Operation Overview

## Section 8. Troubleshooting

### 8.1 Troubleshooting Guide

The following table provides symptoms and solutions for general troubleshooting problems for the heat pump.

SYMPTOM	CORRECTIVE ACTION
Heat pump will not start, no control board display.	Breaker or fuse may be tripped. Reset breaker or check fuse. If heat pump still does not run, call for service. <b>Three-phase models only</b> - The phases may be reversed or there may be a loss of phase, call for service.
Heat pump will not start, control board display working.	Heat pump may be in delay count down of 5 minutes. Make sure control board thermostat is calling for heater to come on (check setting on thermostat and temperature reading). Make sure heat pump is not in cooling mode.
Heat pump runs but does not heat.	Verify cold air is blowing out the top of the heat pump. If the heat pump has just been installed or if the pool water has been allowed to cool significantly, it is necessary to run the heat pump continually for 24-48 hours. If the heat pump has been in operation for some time, increase the circulating pump time, or switch the control board to Maintain Heat function. If heating a spa, verify no air intake stand pipes are open. If heat pump still does not heat, call for service.
Heat pump does not run and control board displays FAULT- LOW WATER FLOW	Verify circulating pump is on and all necessary valves are in the correct positions. Verify filter and skimmers are clean. Check water level in pool. Temporarily turn off all fountains and water falls that bypass the heat pump water inlet. If this does not correct the problem, call for service.
Heat pump does not run and control board display shows FAULT- HIGH REF PRESSURE	Verify circulating pump is on and that there are no water flow restrictions to the heat pump. Make sure all necessary valves are open or in the proper positions to allow proper water flow to the heat pump. Verify filter and skimmers are clean. Check for water level in the pool. This condition may also appear if the heat pump has not been operated for an extended period. To clear the condition, cycle the heat pump, on and off, up to 3 times. If this does not correct the problem, call for service.
Heat pump does not run or short cycles and control board display shows FAULT- LOW REF PRESSURE	Check that fan is operating and air is coming out of the top of the heat pump, while short cycling. If heat pump does not run at all, call for service.
Heat pump leaking water.	Possible heat exchanger or plumbing leak. Turn the heat pump off, then turn circulating pump off for at least one hour to see if the water leak stops. If the water leak stops, normal condensation is occurring. If the water leak continues, after the heat pump is shut off for at least one hour, call for service.

Table 4. Heat Pump Troubleshooting Guide

## 8.2 Diagnostics

In the event a pressure switch opens or another fault condition occurs, the LCD screen will display the fault until the problem has been resolved. Please refer to the following table for the list of diagnostic conditions.

DIAGNOSTIC CONDITION	DESCRIPTION
FAULT- LOW WATER FLOW	<p>Low or restricted water flow through the heat pump.</p> <p>The external bypass valve is in the wrong position, or the water flow switch has malfunctioned. The water flow switch opens creating a fault and the heat pump shuts off.</p>
FAULT- LOW REF PRESSURE	<p>When the ambient temperature is low, the suction pressure can drop significantly.</p> <p>This fault will cause the low pressure switch to open and the control will shut off the compressor.</p>
FAULT- HIGH REF PRESSURE	<p>When the head pressure builds too high, the high pressure switch will open causing the heat pump to shut off immediately.</p> <p>The control will sense this fault condition and shut off the compressor until the switch re-closes.</p>
FAULT- HIGH WATER TEMP	<p>When the POOL or SPA water temperature heats to the maximum allowed temperature or above, there could be safety risks for anyone in the water.</p> <p>The water thermostat will read this temperature and the control will shut off the heat pump unless it is in CHILLER mode.</p> <p>This feature also remains active when the control calls for heat through a remote thermostat. This is to insure that water temperature does not go to an abnormally high level due to a possible malfunction of the remote sensor.</p>
FAULT- SHORTED COIL SENSOR -or- FAULT- OPEN COIL SENSOR	<p>In the event that the coil temperature sensor malfunctions or is not connected the control will shut off the heat pump.</p>
FAULT- SHORTED WATER SENSOR -or- FAULT- OPEN WATER SENSOR	<p>In the event that the water temperature sensor malfunctions or is not connected the control will shut off the heat pump.</p>

**Table 5. Heat Pump Diagnostics**

## Section 9. Replacement Parts

### 9.1 Ordering Information

To order or purchase parts for the AE-Ti models of heat pumps, contact your nearest Jandy dealer or distributor. See the Jandy web site at [www.jandy.com](http://www.jandy.com) for the nearest service center. If they cannot supply you with what you need, contact Jandy Customer Service Department at P.O. Box 6000, Petaluma, California, 94954, Telephone (707) 776-8200 extension 245.

### 9.2 Jandy AE-Ti Heat Pumps Parts List

Key No.	Description	Model No.	Order Part No.
1	Top Enclosure, Jacket	1500	R3009700
1	Top Enclosure, Jacket	2000, 2500, 3000	R3009100
2	Service Access Panel	All	R3000500
3	Control Cover - Smoked	All	R3000601
4	Fan Motor, 1/6 HP, 208 - 230 VAC	1500	R3000703
4	Fan Motor, 1/2 HP, 208 - 230 VAC	2000, 2500, 3000	R3000701
5	Contactora, 1-Phase	All	R3000801
5	Contactora, 3-Phase	2000, 2500, 3000	R3000802
6	Transformer, 240V 24VA	All	R3000901
7	Water Pressure Switch	All	R3001000
8	Capacitor, Fan Motor, 3/370 MFD	1500	R3001101
8	Capacitor, Fan Motor, 7.5/370 MFD	2000, 2500, 3000	R3001100
9	Capacitor, Compressor, 60/370	1500	R3001204
9	Capacitor, Compressor, 80/370	2000, 2500, 3000	R3001203
10	Controller Assembly, Universal	All	R3008800
11	Refrigerant HP Switch	All	R3001400
12	Refrigerant LP Switch	All	R3001500
12	Refrigerant LP Switch (Heat/Cool)	2500,3000	R3001501
13	Wire Harness Kit (Not Shown)	All	R3009000
14	Fan Blade Set	1500	R3001701
14	Fan Blade Set	2000, 2500, 3000	R3001700
15	Fan Guard	1500	R3001801
15	Fan Guard	2000, 2500, 3000	R3001800
16	Plumbing Bypass Assembly	All	R3001900
17	2" PVC Union Set	All	R3002000
18	Evaporator Coil/Guard	1500	R3002104
18	Evaporator Coil/Guard	2000	R3002101
18	Evaporator Coil/Guard	2500	R3002102
18	Evaporator Coil/Guard	3000	R3002103
19	Heat Exchanger Drain Kit (Not Shown)	All	R3002200
20	Heat Exchanger Replacement Kit	1500	R3009900
20	Heat Exchanger Replacement Kit	2000, 2500, 3000	R3002300
21	Compressor (40K), 1-Phase	1500	R3009800
21	Compressor (60K), 1-Phase	2000	R3002500
21	Compressor (68K), 1-Phase	2500	R3002600
21	Compressor (81K), 1-Phase	3000	R3002700
21	Compressor (60K), 3-Phase	2000	R3003400
21	Compressor (68K), 3-Phase	2500	R3003500
21	Compressor (81K), 3-Phase	3000	R3003600
22	Thermal Expansion Valve, 2 1/2 Ton (Not Shown)	1500	R3002803
22	Thermal Expansion Valve, 5 Ton (Not Shown)	2000, 2500	R3002801
22	Thermal Expansion Valve, 5 Ton, Adjustable (Not Shown)	2500, 3000	R3002802
23	Water Temperature Sensor	All	R3002900
24	3-Phase Monitor (3-Phase Models Only) (Not Shown)	2000, 2500, 3000	R3003000
25	Air Temperature Sensor	All	R3003100
26	Reversing Valve (Optional, Not Shown)	2500,3000	R3003800
27	Achor Bracket Set (Not Shown)	All	R3003203
28	Heat Pump Drain Kit (Not Shown)	All	R3004100
29	Junction Box Cover	All	R3004600
30	Power Interface PCB	All	R3009200
31	Fan Relay	All	R3009300

9.3 Jandy AE-Ti Heat Pumps Exploded View

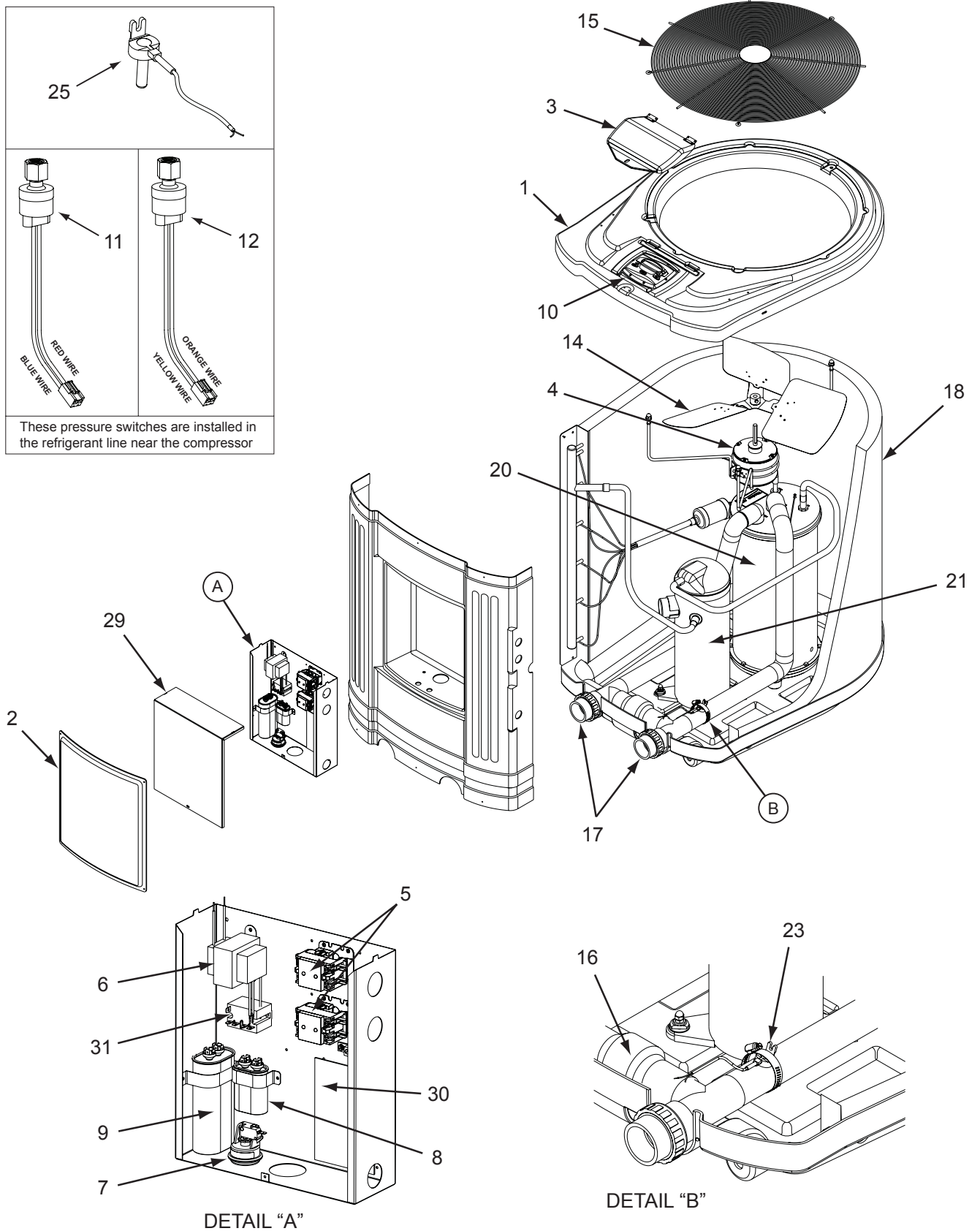

Figure 18. Jandy AE-Ti Heat Pumps Exploded View

## LIMITED WARRANTY

Thank you for purchasing Jandy® pool and spa products. Jandy Pool Products, Inc. (manufacturer of pool and spa heaters, Air Energy Heat Pumps, and Clormatic Electronic Chlorine Generators) warrants all parts to be free from manufacturing defects in materials and workmanship for a period of one year from the date of retail purchase, with the following exceptions:

- AquaLink® RS units installed with Jandy Surge Protection Kits will be covered for two years.
- NeverLube® valves are warranted for the life of pool and/or spa on which they were originally installed.
- AquaPure™ Electronic Chlorine Generator Electrolytic Cells carry a 5 year limited warranty on a prorated basis.
- Heat pump titanium coils carry a limited lifetime warranty.

This warranty is limited to the first retail purchaser, is not transferable, and does not apply to products that have been moved from their original installation sites. The liability of Jandy Pool Products, Inc. shall not exceed the repair or replacement of defective parts and does not include any costs for labor to remove and reinstall the defective part, transportation to or from the factory, and any other materials required to make the repair. This warranty does not cover failures or malfunctions resulting from the following:

1. Failure to properly install, operate or maintain the product(s) in accordance with our published Installation, Operation and Maintenance Manuals provided with the product(s).
2. The workmanship of any installer of the product(s).
3. Not maintaining a proper chemical balance in your pool and/or spa [pH level between 7.2 and 7.8, Total Alkalinity (TA) between 80 to 120 ppm, Total Dissolved Solids (TDS) less than 2000].
4. Abuse, alteration, accident, fire, flood, lightning, rodents, insects, negligence or acts of God.
5. Scaling, freezing, or other conditions causing inadequate water circulation.
6. Operating the product(s) at water flow rates outside the published minimum and maximum specifications.
7. Use of non-factory authorized parts or accessories in conjunction with the product(s).
8. Chemical contamination of combustion air or improper use of sanitizing chemicals, such as introducing sanitizing chemicals upstream of the heater and cleaner hose or through the skimmer.
9. Overheating; incorrect wire runs; improper electrical supply; collateral damage caused by failure of O-Rings, DE grids, or cartridge elements; or damage caused by running the pump with insufficient quantities of water.

### LIMITATION OF LIABILITY:

This is the only warranty given by Jandy Pool Products, Inc. No one is authorized to make any other warranties on Jandy Pool Products, Inc.'s behalf. **THIS WARRANTY IS IN LIEU OF ALL OTHER WARRANTIES, EXPRESSED OR IMPLIED, INCLUDING BUT NOT LIMITED TO ANY IMPLIED WARRANTIES OF FITNESS FOR A PARTICULAR PURPOSE AND MERCHANTABILITY. JANDY POOL PRODUCTS, INC. EXPRESSLY DISCLAIMS AND EXCLUDES ANY LIABILITY FOR CONSEQUENTIAL, INCIDENTAL, INDIRECT OR PUNITIVE DAMAGES FOR BREACH OF ANY EXPRESSED OR IMPLIED WARRANTY.** This warranty gives you specific legal rights. You may also have other rights which vary by state or province.

### WARRANTY CLAIMS:

For prompt warranty consideration, contact your dealer and provide the following information: proof of purchase, model number, serial number and date of installation. The installer will contact the factory for instructions regarding the claim and to determine the location of the nearest designated service center. If the dealer is not available, you can locate a service center in your area by visiting [www.jandy.com](http://www.jandy.com) or by calling our technical support department at (707) 776-8200 extension 260 [for heat pumps call (954) 970-4800]. All returned parts must have a Returned Material Authorization number to be evaluated under the terms of this warranty.



Jandy Pool Products, Inc.

6000 Condor Drive • Moorpark, CA USA 93021 • 707.776.8200 • Fax 707.763.7785  
2735 NW 63rd CT • Fort Lauderdale, FL USA 33309 • 954.970.4800 • Fax 954.971.8440

Litho in U.S.A. © Jandy Pool Products, Inc. 0703