

OWNER'S MANUAL

INSTALLATION, OPERATION, & PARTS



Before installation, be sure to read all instructions and warnings carefully.

Refer to product dataplate(s) for additional operating instruction and specifications.

Inspection

Examine the equipment when received. Notify your dealer or carrier of any damage or missing parts. Verify that equipment is of size and model specified.

Important Safety Instructions

When installing and using this electrical equipment, basic safety precautions should always be followed, including the following:

1. READ AND FOLLOW ALL INSTRUCTIONS.
2. WARNING – To reduce risk of injury, do not permit children to use this product unless they are closely supervised at all times.
3. WARNING – (For cord & plug connected units). Risk of Electrical Shock. Connect only to a grounding type receptacle protected by a ground-fault circuit-interrupter (GFCI). Contact a qualified electrician if you cannot verify that the receptacle is protected by a GFCI.
4. WARNING – (For cord & plug connected units). Do not bury cord. Locate cord to minimize abuse from lawn mowers, hedge trimmers and other equipment.
5. WARNING – (For cord & plug connected units). To reduce the risk of electric shock, replace damaged cord

immediately.

6. **WARNING** – (For cord & plug connected units). To reduce the risk of electrical shock do not use an extension cord to connect unit to electrical supply; provide a properly located outlet.
7. **CAUTION** – (For pumps with a 25 ft. (7.62m cord). This pump is for use with storable pools only. Do not use with permanently installed pools. A storable pool is constructed so that it may be readily disassembled for storage and reassembled to its original integrity. A permanently installed pool is constructed in or on the ground or in a building such that it cannot be readily disassembled for storage.
8. **CAUTION** – (For pumps with/without 3ft.(91m cord) or 6ft.(1.82m cord). This pump is for use with permanently installed pools and may also be used with hot tubs and spas if so marked. Do not use with storable pools. A permanently installed pool is constructed in or on the ground or in a building such that it cannot be readily disassembled for storage. A storable pool is constructed so that it may be readily disassembled for storage and reassembled to its original integrity.
9. **WARNING** – (For hot tub and spa pumps). Do not install within an outer enclosure or beneath the skirt of the hot tub or spa, unless so marked.
10. **SAVE THESE INSTRUCTIONS!**

Installation Location

Locate pump as close to pool/spa as possible, preferably in a dry, well ventilated area away from direct sunlight. It should be on a hard, level surface. Give consideration to:

1. Drainage – away from pump.
2. Ventilation of pump motor.
3. Access for future servicing and winterizing.
4. Protection from the elements.

Pumps without strainer bodies are designed for flooded suction (all suction fittings and suction piping below water level) and will not self-prime. Consequently, the pump must be installed at an elevation that is below water level when pool or spa is filled; however, if suction line valves are installed, the pump may be closed for priming. Keep vertical distance to a minimum if you choose to mount pump above water level.

Pumps with strainer bodies are self-priming but should be mounted as close to the water level as possible or below for ease in priming.

General Plumbing

FOR SOLVENT WELD CONNECTION

Rigid or flexible PVC pipe can be used. Pipe ends should be clean and free of any flash cause by the cutting operation. Be sure that the proper adhesive is used on the type of pipe specified.

Note: A primer will assure that adhesive joints are superior. Suregard P-3000 has a purple tracer to qualify in areas where codes specify a primer must be used.

Caution: We recommend that you consider climatic conditions when applying adhesives. Certain atmospheric situations, such as high moisture content, make adhesive action of certain glues less effective. Check the manufacturer's instructions.

FOR THREADED CONNECTIONS

Use only Teflon tape or equivalent on threaded plumbing connections. Other pipe compounds may damage threads. We do not recommend the use of silicone or petroleum based compounds. **DO NOT OVERTIGHTEN – HAND TIGHTEN PLUS ½ TURN IS SUFFICIENT.**

Pump Plumbing

Suction pipe should be as large or larger than discharge pipe. Avoid using suction pipe smaller than pump connection.

Keep the piping as straight and short as possible, and of suitable size. Avoid connecting an elbow directly into the pump inlet (use a length of straight pipe to allow a proper entry for the water). Arrange horizontal runs to slope upward to the pump to prevent high spots that could form air pockets. Support the pipe independently so that it places no strain on the pump. Keep as much of the suction line as possible below the water level to reduce priming time. Install valves and unions in the pump suction and return lines to facilitate servicing. Valves are recommended for throttling

maintenance if the system is installed below deck level. Suction valves are essential for priming all pumps without strainer bodies installed above water level. Pumps with

strainer bodies are self-priming, nevertheless, we recommend the use of check valve in the suction pipe at or below the water level if the suction lift is more than five feet or if the dry suction is more than ten feet long. Keep the valve in the suction line fully open during operation.

Electrical Data

Refer to information on motor nameplate for electrical service data. All motors should have fused disconnect switch or circuit breaker. Be sure wire size is sufficient for pump HP and distance from power source. Wiring should be done in accordance with applicable codes by a competent electrician.

We recommend the installation of a ground fault circuit interrupter for maximum safety.

Pump Start Up

Do not operate pump until it has been primed as water acts to cool and lubricate the seal. For pumps without strainer bodies and located above water, close suction line valve and fill pump with water in order to prime. For pumps with strainer bodies and located above water, prime by removing strainer cover and filling strainer body with water. Pumps located below water level will self-prime if all piping is also below water level. After pump has been primed, energize motor and open all suction and discharge line valves. It may take some time for pump to remove air from suction lines. If no flow is observed in five minutes, stop the motor and re-prime. If the pump fails to operate, check for air leaks. Refer to Trouble Shooting section.

After about ten minutes of operation, check the return fittings for air bubbles. A continuous flow of air indicates leaks in suction line. Locate and correct any leaks immediately.

CONTROLLING THE OUTPUT

Keep the gate valve in the suction line fully open during operation. Should it be necessary to control the output, use a valve in the return line.

Caution: Do not retighten strainer Ring-Lok during operation.

Caution: Do not operate pump with closed suction or discharge valves.

Two-Speed Pumps

Two-speed models are recommended in a swimming pool when high speed is needed for maximum filtration at peak periods and whenever turbidity levels are high. At other times, switch to low speed. For backwashing and vacuuming, high speed is required.

In spas and hot tubs, use high speed to attain full performance in the hydro-therapy mode. At other times, such as filter/heat cycle mode, use low speed. Low speed provides sufficient flow to activate most spa heaters and

provides sufficient flow for filtration.

In jetted tubs, use high speed to attain full performance in the hydro-therapy mode and use low speed mode to prime. **The below picture shows how to switch between the high speed and low speed.**

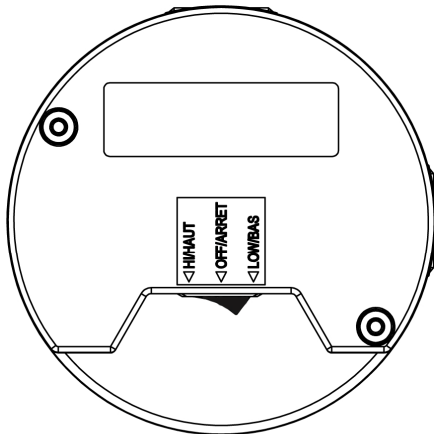

High speed

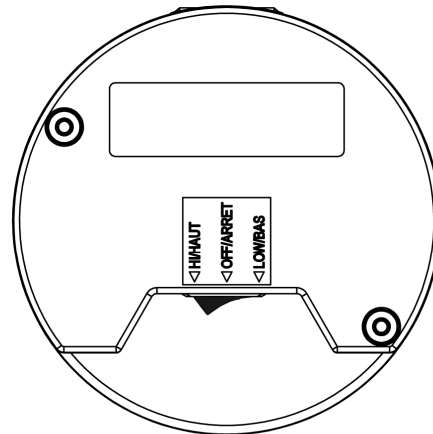

Low speed

ON-OFF Single-Speed Pumps

In order to have a safer and quicker start of the swimming pool filtration systems (or pumps), it is very necessary to install ON-OFF switch. Without it, every start or shut down need to plug/unplug the power cord, it will cause a lot of safety risks, such as, spark occurs when plug/unplug the power cord and frequent plug/unplug will cause poor contact between plug and socket. The below picture shows how to switch between ON and OFF.

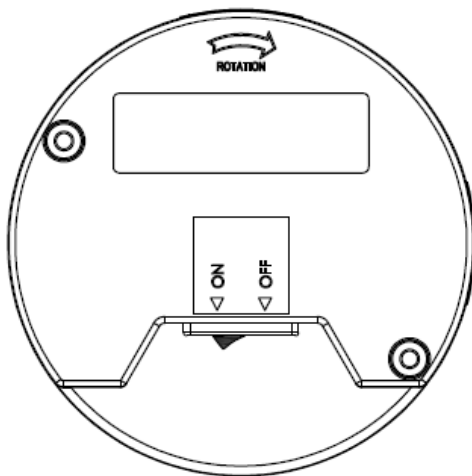

ON

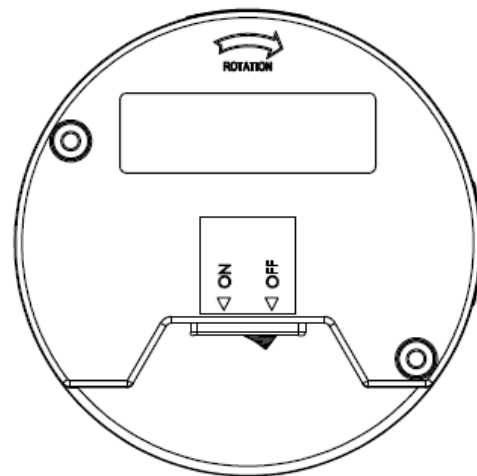

OFF



Winterizing

Consult your dealer for advice on winterizing your equipment if freezing temperatures occur in your locality. His knowledge of your equipment makes him the best qualified source of information. Follow his recommendations, and if these include draining the

filter system, proceed as follows:

1. If your system does not contain a filter, proceed to step2.
 - A. For sand filters: BACKWASH for 3 to 5 minutes and set dial valve to WINTERIZE.
 - B. For cartridge filters: Clean the filter element and

store in a dry place.

2. Drain system by loosening drain plugs (drain plugs will drain without completely removing the plug from unit) and/or removing pipe caps.

Water Chemistry

A proper and consistent use of chemicals is necessary to maintain clean, sanitary water, prevent a spread of germ infection and control the growth of algae which can spoil the appearance and enjoyment of your pool or spa.

Chlorine is the most commonly used chemical to provide clean, sanitary water. Either dry or liquid chlorine (calcium or sodium hypochlorite) can be used which should be added daily as it is dissipated by dirt and germs as well as by the sun and wind.

It is also important that the correct level of acidity or alkalinity of the pool water be maintained. This is the pH of your pool with pH 7.0 being neutral. Readings above 7.0 are alkaline and below are acid. A desirable range is 7.2 – 7.4.

Pump Maintenance

1. Motors are self-lubricating – no lubrication required.
2. Clean hair & lint strainer if you have a strainer body pump.
3. Visually inspect motor for blockage of air vents on motor shell. Remove any debris after breaker off.
4. Shaft seals may become worn and must be replaced if leakage is observed.

Cleaning

Switch power off. Close valves in suction and return line. Unscrew strainer Ring-Lok counterclockwise and remove the strainer cover from hair and lint strainer and lift out strainer basket. Clean and replace the basket. Take care to seat basket properly. Clean O-Ring and re-lubricate with petroleum jelly if necessary. Clean O-Ring seats on cover and strainer. Refit cover and strainer – hand tighten only – and open valves. Put pump back into operation.

Caution: Do not retighten strainer during operation.

Service & Repair Parts

Refer all service to your local dealer as his knowledge of your equipment makes him the best qualified source of information. Order all repair parts through your dealer. Give the following information when ordering repair parts:

1. Unit nameplate data.
2. Description of part.

Trouble Shooting

MOTOR DOES NOT START

1. Disconnect switch or circuit breaker in OFF position.
2. Fuses blown or thermal overload open. Locked motor shaft.
3. Motor windings burned out.
4. Defective starting switch inside single-phase motor
5. Disconnected or defective wiring
6. Low voltage

MOTOR DOES NOT REACH FULL SPEED

1. Low voltage
2. 2 speed model set on low speed
3. Motor windings connected for wrong voltage on dual voltage model.

MOTOR OVERHEATS (Protect trips)

1. Low voltage
2. Motor windings connected for wrong voltage on dual voltage model.
3. Inadequate ventilation

PUMP DELIVERS NO WATER

1. Pump is not primed
2. Closed valve in suction or discharge line
3. Leakage or air into suction system
4. Impeller clogged

LOW PUMP CAPACITY

1. Valve in suction or discharge line partly closed
2. Suction or discharge line partly plugged
3. Suction or discharge line too small
4. Pump running at reduced speed (see above)
5. Plugged basket in skimmer or hair and lint strainer
6. Dirty filter
7. Impeller clogged

8. Wrong rotation (3 phase only)

5. Vacuum hose plugged or too small

6. Pump not supported properly

LOW PUMP PRESSURE

1. Pump running at reduced speed (see above)
2. Wrong rotation (3 phase only)
3. Discharge valve or inlet fittings closed too much

LEAKAGE OF WATER AT SHAFT

1. Shaft seal requires replacement

HIGH PUMP PRESSURE

1. Discharge valve or inlet fittings closed too much
2. Return lines too small
3. Dirty filters

AIR BUBBLES AT INLEY FITTINGS

1. Leakage air into suction line at connections or valve stem
2. Cover gasket of hair and lint strainer needs cleaning
3. Restriction in suction line
4. Low water level in pool

NOISY PUMP AND MOTOR

1. Plugged basket in skimmer or hair in lint strainer
2. Worn motor bearings
3. Valve in suction line partly closed
4. Suction line partly plugged

NOTE: If the recommendations in the Trouble Shooting portion of this manual do not solve your particular problem(s), please contact your local dealer for service.

TECHNICAL DATA

Model	HP	RPM	Volte / HZ	Amps	Remark
72712/72713	1/4 HP	3450	115V/60HZ	2.5	Single- speed
72714/72715	1/3 HP	3450	115V/60HZ	3.6	
72720	1/2 HP	3450	115V/60HZ	5	
72721	1/2 HP	3450	115V/60HZ	5	
72728	0.75HP SPL	3450	115V/60HZ	7.3	
72729	1.0HP SPL	3450	115V/60HZ	9	
72729S	1.0HP SPL	3450	115V/60HZ	9	
72730	1.5HP SPL	3450	115V/60HZ	12	
72730S	1.5HP SPL	3450	115V/60HZ	12	
72742	0.75 HP	3450	115V/60HZ	9.2	
72743	1.0 HP	3450	115V/230V/60HZ	11.5/5.7	
72744	1.5 HP	3450	115V/230V/60HZ	14/7	
72747	1.0 HP	3450	115V/230V/60HZ	11.5/5.7	
72748	1.5 HP	3450	115V/230V/60HZ	14.2/7.1	
72726	1.0HP SPL	3450/1720	115V/60HZ	10A/3.2A	Two- speed
72727	1.5HP SPL	3450/1720	115V/60HZ	12A/3.6A	
72749	0.75 HP	3450/1720	115V/60HZ	10A/3.2A	
72750	1.0 HP	3450/1720	115V/60HZ	12A/3.6A	
72751	1.5 HP	3450/1720	230V/60HZ	7.5A/2.1A	
72754	1.0 HP	3450/1720	115V/60HZ	12A/3.6A	
72755	1.5 HP	3450/1720	230V/60HZ	7.5A/2.1A	

Parts Listing:72712 / 72714/72720

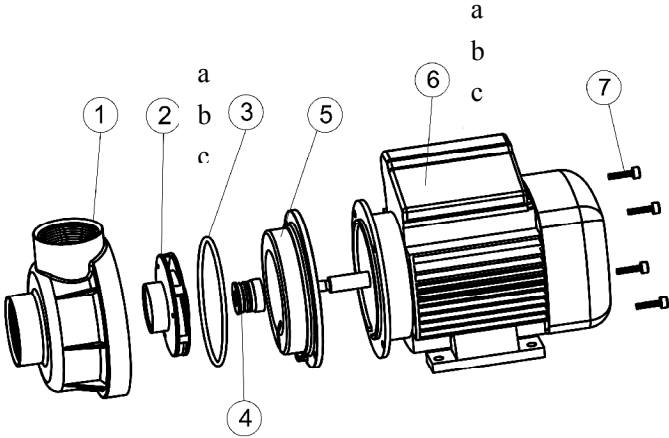

Ref. No.	Part No.	Description	QTY
1	647251201080	Pump housing	1
2a	647271271000	Impeller for 72712	1
2b	647251271000	Impeller for 72714	1
2c	647272071000	Impeller for 72720	1
3	65431069080	o-ring	1
4	65028013000	Seal assembly	1
5	647251202080	Pump cover	1
6a	65023017000	0.25HP motor for 72712	1
6b	65023018000	0.35HP motor for 72714	1
6C	65023151000	0.5HP motor for 72720	1
7	65224024000	Screw M5X20	4

Parts Listing:72713 / 72715/72721

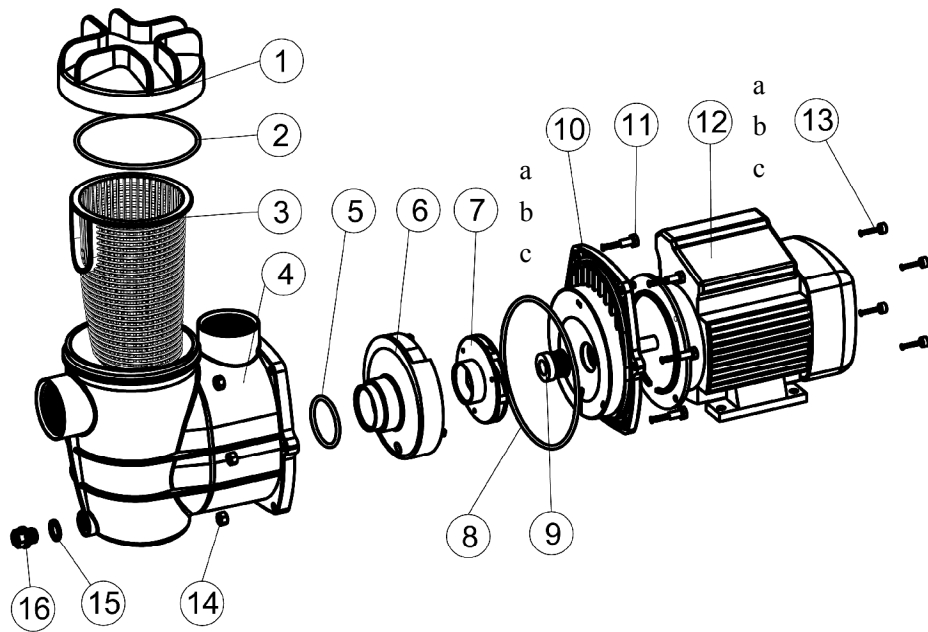

Ref. No.	Part No.	Description	QTY
1	647251503000	Cover	1
2	65431071080	o-ring	1
3	647251507001	basket	1
4	647251501080	Pump housing	1
5	65431070080	o-ring	1
6	647251504080	diffuser	1
7a	647271271000	Impeller for 72713	1
7b	647251271000	Impeller for 72715	1
7C	647272071000	Impeller for 72721	
8	65431037080	o-ring	1
9	65028013000	Seal assembly	1
10	647251502080	Pump cover	1
11	65224004000	Screw M6X25	6
12a	65023017000	0.25HP motor for 72713	1
12b	65023018000	0.35HP motor for 72715	1
12C	65023151000	0.5HP motor for 72721	1
13	65224025000	Screw M5X14	4
14	65231002000	Nut M6	6
15	65432002080	gasket	1
16	88601007000	Drain plug	1

Parts Listing:72728 / 72729 / 72729S/72730/72730S / 72726 / 72727

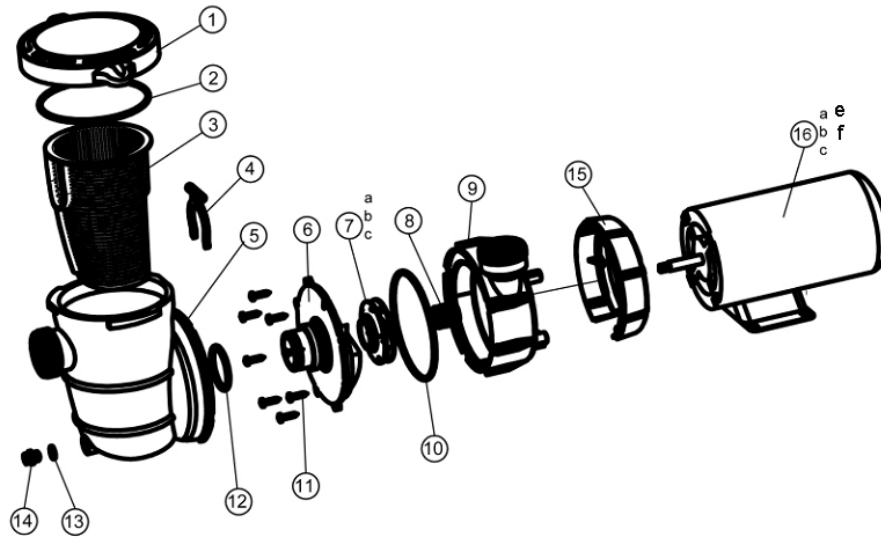

Ref. No.	Part No.	Description	QTY
1	647252772000	Cover	1
2	65431042080	o-ring	1
3	647252704001	Basket	1
4	647252705080	Clip	1
5	647252703080	Strainer housing	1
6	647252702080	Pump cover	1
7a	647272871000	Impeller for 72728	1
7b	647272971000	Impeller for 72729 / 72729S/72726	1
7c	647252771000	Impeller for 72730 / 72730S/72727	1
8	65028003000	Seal assembly	1
9	647252701080	Pump housing	1
10	65431040080	o-ring	1
11	65212016000	Screw ST5.5X25	8
12	65431029080	O-RING	1
13	65432002080	gasket	1
14	648860105080	Drain plug	1
15	647252708080	Motor mounting plate	1
16a	65023005000	0.75HP motor for 72728	1
16b	65023006000	1.0HP motor for 72729/72729S	1
16c	65023007000	1.5 HP motor for 72730/72730S	1
16e	65023081000	1.0HP two-speed motor for 72726	1
16f	65023084000	1.5 HP two-speed motor for 72727	1

Parts Listing:72742 / 72743 / 72744 / 72749 / 72750 / 72751

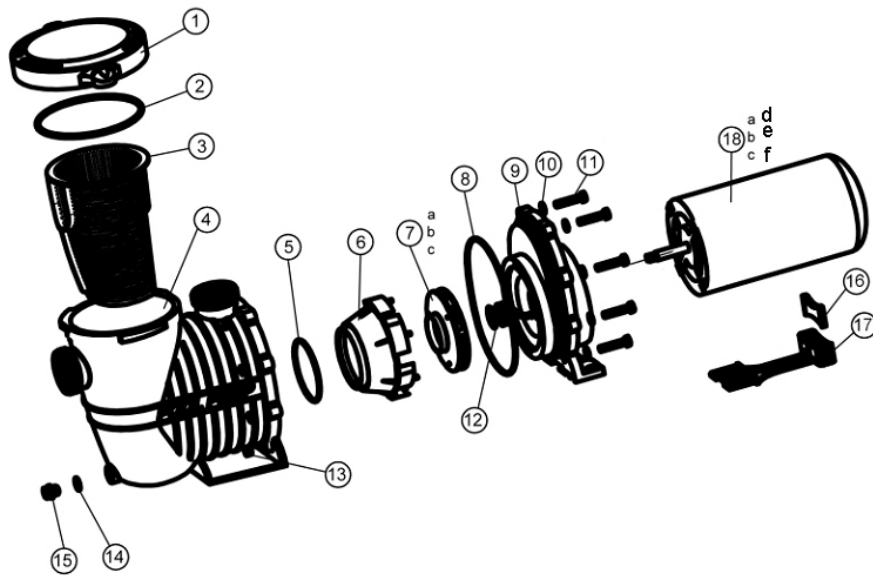

Ref. No.	Part No.	Description	QTY
1	647252772000	Cover	1
2	65431042080	o-ring	1
3	647252704001	Basket	1
4	647254201080	Pump housing	1
5	65431032080	o-ring	1
6	647254203080	Diffuser	1
7a	647274271000	Impeller for 72742 / 72749	1
7b	647274371000	Impeller for 72743 / 72750	1
7c	647254271000	Impeller for 72744 / 72751	1
8	65431075080	o-ring	1
9	647254202080	Pump cover	1
10	65244005000	gasket M8	8
11	65221009000	Screw M8X40	8
12	65028003000	Seal assembly	1
13	65231004106	Nut M8	8
14	65432002080	gasket	1
15	648860105080	Drain plug	1
16	647254205080	Foot insert wfe pump	1
17	647254204080	Mounting foot	1
18a	65023019000	0.75HP motor for 72742	1
18b	65023020000	1.0HP motor for 72743	1
18c	65023021000	1.5HP motor for 72744	1
18d	65023087000	0.75HP two-speed motor for 72749	1
18e	65023088000	1.0HP two-speed motor for 72750	1
18f	65023085000	1.5HP two-speed motor for 72751	1

Parts Listing:72747 / 72748 / 72754 / 72755

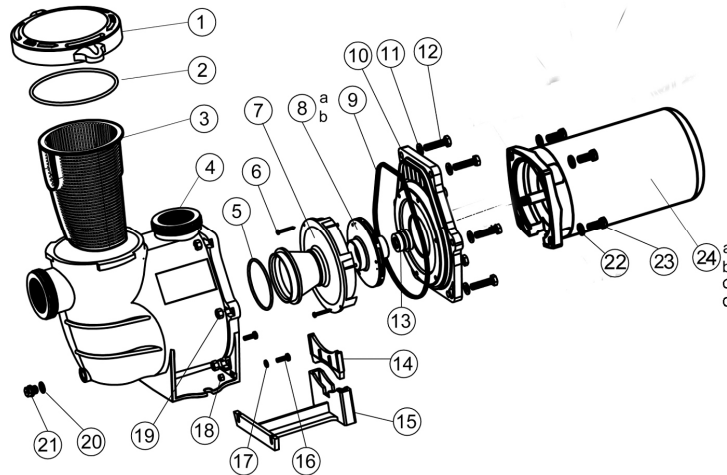

Ref. No.	Part No.	Description	QTY
1	647252772000	Cover	1
2	65431042080	o-ring	1
3	647252704001	Basket	1
4	647254701080	Pump housing	1
5	65431032080	o-ring	1
6	65212025000	Screw ST4.2X38	2
7	647254703080	Diffuser	1
8a	647274771000	Impeller for 72747 / 72754	1
8b	647274871000	Impeller for 72748 / 72755	1
9	65431074080	o-ring	1
10	647254702080	Pump cover	1
11	65244015000	Gasket M10	6
12	65225003000	Screw 3/8-16*1 1/2 UNC	6
13	65028014000	Seal assembly	1
14	647254705080	Foot insert wfe pump	1
15	647254704080	Mounting foot	1
16	65224003000	Screw M6X20	2
17	65244016000	Gasket M6	2
18	65231002106	Nut M6	2
19	65232001106	Nut 3/8-16	6
20	65432002080	Gasket	1
21	648860105080	Drain plug	1
22	65244015000	Gasket M10	4
23	65221008000	Screw M10X25	4
24a	65023022000	1.0HP motor for 72747	1
24b	65023023000	1.5HP motor for 72748	1
24c	65023083000	1.0HP two-speed motor for 72754	1
24d	65023086000	1.5HP two-speed motor for 72755	1